

## Twin-piston semi-rotary drives DRRD

**FESTO**



Festo core product range  
Covers 80% of your automation tasks

Worldwide:

Always in stock

Superb:

Festo quality at an attractive price

Easy:

Reduces procurement and storing complexity

★ Ready for dispatch from the Festo factory in 24 hours  
Held in stock in 13 service centres worldwide  
More than 2200 products

★ Ready for dispatch in 5 days maximum from stock  
Assembled for you in 4 service centres worldwide  
Up to 6 x 10<sup>12</sup> variants per product series

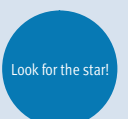

# Twin-piston semi-rotary drives DRRD

Features

## At a glance

- Rack and pinion principle
- Very high accuracy in the end positions
- Very high bearing load capacity
- Very good axial run-out at the flanged shaft
- High mass moments of inertia
- Low backlash and good dynamic response
- Splash-proof design to IP65 based on EN 60529
- Defined interfaces
- Supply port at one end
- Choice of mounting options
- Ideal for use in handling applications

## Wide choice of variants

### Flanged shaft



- Size 8 ... 63
- Torque: 0.2 ... 112 Nm
- Swivel angle: 0 ... 180°

### Drive shaft



- Size 12 ... 40
- Torque: 0.8 ... 24.1 Nm
- Swivel angle: 0 ... 180°
- Suitable for ATEX
- Can be ordered as an accessory

### Position sensing



- Size 8 ... 12
  - C-slot for proximity sensor SMT/SME-10
- Size 16 ... 63
  - T-slot for proximity sensor SMT/SME-8

### External position sensing (sensor mounting)



- Size 16 ... 63
- Position sensing possible directly at the flanged shaft
- Inductive proximity sensors SIES can be used in combination with external position sensing

### Cushioning



- Size 12 ... 63
- Five cushioning types available:
  - Elastic cushioning with metal end position (P)
  - Shock absorber (Y9)
  - Shock absorber, hard (Y10)
  - Shock absorber, external (Y12)
  - Shock absorber, soft (Y14)

### External cushioning



- Size 12 ... 63
- The full torque can be realised in the end positions in combination with external cushioning

### Energy throughfeed



- Size 16 ... 63
- Electrical signals or compressed air can be transferred through the hollow shaft using the energy throughfeed. This enables fast and easy supply of the parts connected to the flange (e.g. gripper)

Also suitable for IO-Link signal data transfer.

### Intermediate position



- Size 16 ... 50
- The semi-rotary drive can additionally be positioned at 90° using the intermediate-position module.
- The intermediate position can be approached from both directions
- The cushioning for the intermediate position corresponds to the cushioning for the basic drive. Except in the case of cushioning Y12, when shock absorbers Y9 are used

### End-position locking



- Size 16 ... 63
- Mechanical lock in the end positions to prevent unwanted movement in unpressurised condition

# Twin-piston semi-rotary drives DRRD

System example

## Mounting options

Via through-holes

Via thread in the housing profile

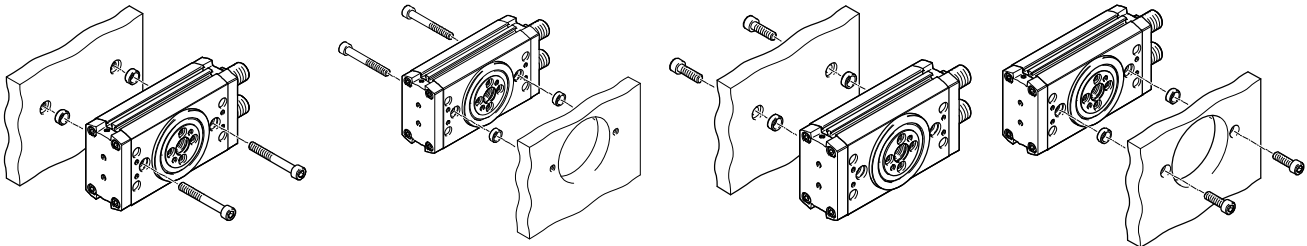

## System product for handling and assembly technology

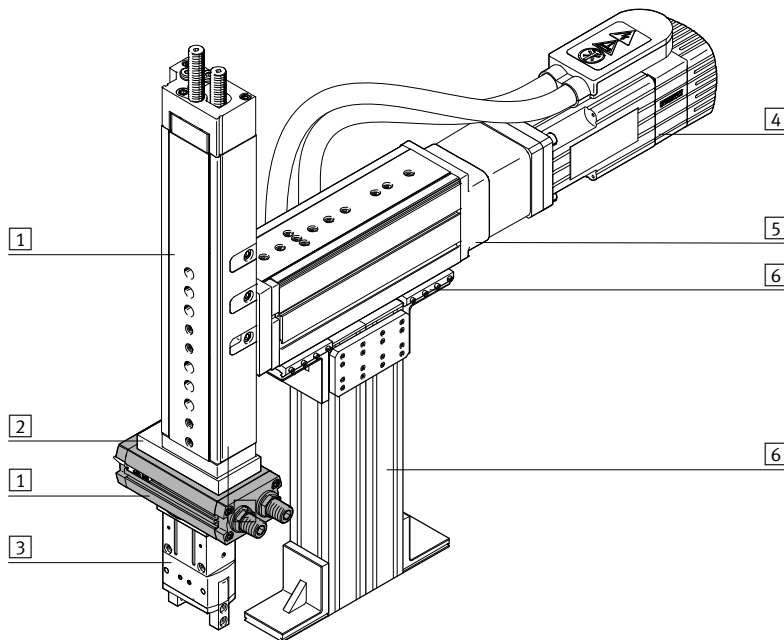

## System components and accessories

	Description	→ Page/Internet
1	Drives	drive
2	Adapters	adapter kit
3	Grippers	gripper
4	Motors	motor
5	Axes	axis
6	Basic components	base component
-	Installation components	installation component

# Twin-piston semi-rotary drives DRRD

Product range overview

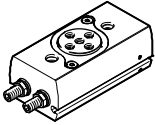
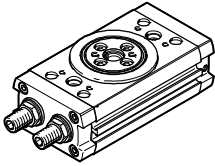
Function	Version	Size	Swivel angle	Energy throughfeed					
				[°]	P2	P2E2	P4	P4E6	P8
Double-acting	<b>DRRD-8 ... 12</b>								
		8	Max. 200	-	-	-	-	-	-
		10	Max. 200	-	-	-	-	-	-
		12	Max. 200	-	-	-	-	-	-
	<b>DRRD-16 ... 63</b>								
		16	Max. 200	■	■	-	-	-	-
		20	Max. 200	■	■	-	-	-	-
		25	Max. 200	-	-	■	■	-	-
		32	Max. 200	-	-	■	■	-	-
		35	Max. 200	-	-	■	■	-	-
		40	Max. 200	-	-	-	-	■	■
		50	Max. 200	-	-	-	-	■	■
		63	Max. 200	-	-	-	-	■	■

## Product options

Energy throughfeed

P2 Pneumatic, 2 channels

P2E2 Pneumatic, 2 channels; electric, 2 signals

P4 Pneumatic, 4 channels

P4E6 Pneumatic, 4 channels; electric, 6 signals

P8 Pneumatic, 8 channels

P8E8 Pneumatic, 8 channels; electric, 8 signals

# Twin-piston semi-rotary drives DRRD

Product range overview

Function	Size	Cushioning					Position sensing	EU certification	Intermediate position	End-position locking	Sensor mounting, external	Splash-proof design	→ Page/ Internet
		P	Y9	Y10	Y12	Y14							
Double-acting	DRRD-8 ... 12												
	8	■	-	-	-	-	■	-	-	-	-	-	7
	10	■	-	-	-	-	■	-	-	-	-		
	12	■	■	-	■	-	■	-	-	-	-		
	DRRD-16 ... 63												
	16	■	■	-	■	■	■	■	■	■	■	■	18
	20	■	■	-	■	■	■	■	■	■	■	■	
	25	■	■	■	■	■	■	■	■	■	■	■	
	32	■	■	-	■	■	■	■	■	■	■	■	
	35	■	■	■	■	■	■	■	■	■	■	■	
	40	■	■	■	■	■	■	■	■	■	■	■	
	50	-	■	■	■	-	■	■	■	■	■	■	
	63	-	■	■	■	-	■	■	-	■	■	■	

## Product options

### Cushioning

- P Elastic cushioning at both ends
- Y9 Linear shock absorber, self-adjusting at both ends, internal
- Y10 Linear shock absorber, self-adjusting at both ends, hard, internal
- Y12 Linear shock absorber, self-adjusting at both ends, external
- Y14 Linear shock absorber, self-adjusting at both ends, soft, internal

# Twin-piston semi-rotary drives DRRD-8 ... 12

Peripherals overview

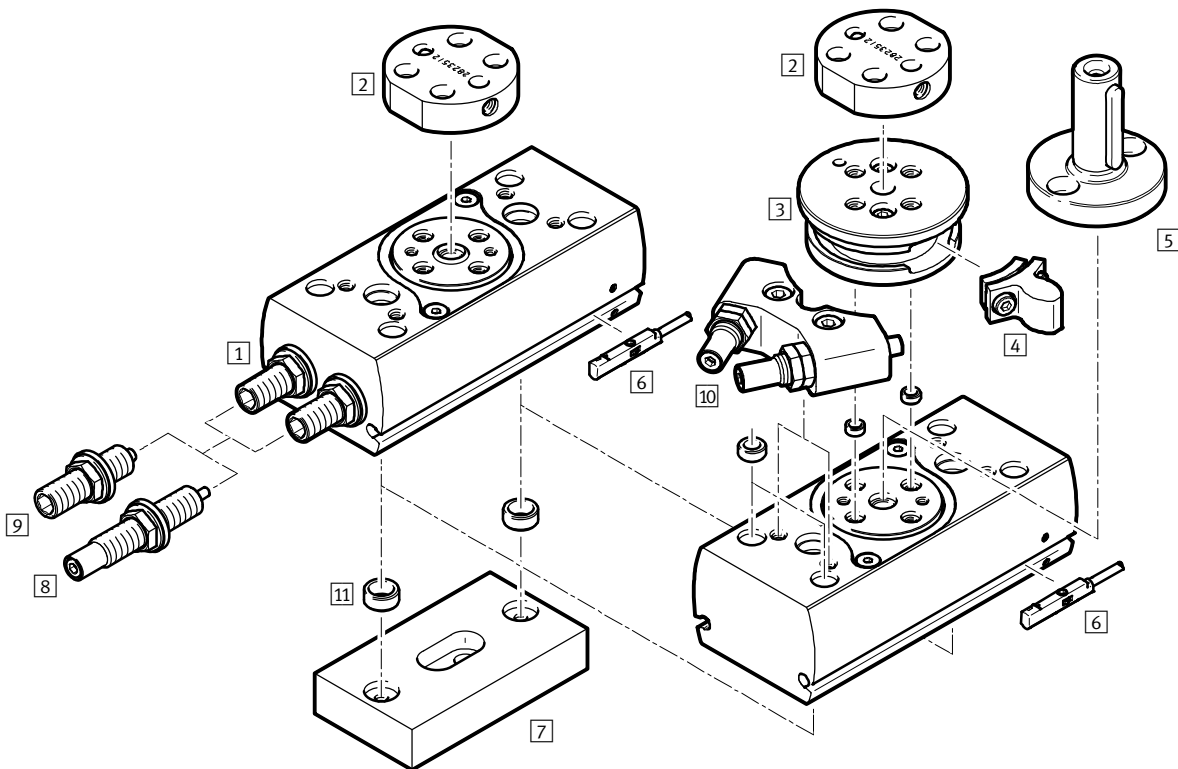

Variants, mounting components and accessories		Size			→ Page/ Internet	
	Description	8	10	12		
1	Semi-rotary drive DRRD	Double-acting	■	■	■	7
2	Adapter kit DHAA	<ul style="list-style-type: none"> <li>Connecting plate between semi-rotary drive and gripper</li> <li>Included in the scope of delivery: 2 centring sleeves and screws</li> </ul>	■	■	■	gripper
3	Flange assembly	<ul style="list-style-type: none"> <li>Required for the fastening of component 4</li> </ul>	-	-	■	16
4	Stop element	<ul style="list-style-type: none"> <li>Serves as an end stop in combination with external shock absorbers (Y12)</li> <li>Two stop elements are included in the scope of delivery of external shock absorbers (Y12)</li> </ul>	-	-	■	16
5	Drive shaft DARF-Q11	<ul style="list-style-type: none"> <li>The interface corresponds with that of semi-rotary drive DRQD.</li> <li>The drive shaft can only be mounted directly on the flanged shaft.</li> <li>Suitable for ATEX</li> </ul>	-	-	■	56
6	Proximity sensor SMT/SME-10	For sensing the piston position	■	■	■	60
7	Adapter kit DHAA	Connecting plate between semi-rotary drive and drive	■	■	■	65
8	Shock absorber Y9	Linear shock absorber, self-adjusting at both ends	-	-	■	17
9	Shock absorber P	Elastic cushioning with metal end position, both ends	■	■	■	17
10	Shock absorber, external Y12	<ul style="list-style-type: none"> <li>Linear shock absorber, self-adjusting at both ends, external</li> <li>Included in the scope of delivery: 3, 2x 4, 10</li> </ul>	-	-	■	17
11	Centring sleeve ZBH	For centring attachments (two centring sleeves for mounting the semi-rotary drive included in the scope of delivery)	■	■	■	59

# Twin-piston semi-rotary drives DRRD-8 ... 12

Type codes

DRRD - [ ] - 180 - FH - [ ] - [ ] - [ ]

**Product type**

Double-acting	
DRRD	Semi-rotary drive

**Size**

**Nominal swivel angle**

180	180°
-----	------

**Output shaft**

FH	Flanged shaft, hollow
----	-----------------------

**Cushioning**

P	Elastic cushioning at both ends
Y9	Linear shock absorber, self-adjusting at both ends, internal
Y12	Linear shock absorber, self-adjusting at both ends, external

**Position sensing**

A	Via proximity sensors
---	-----------------------

**Operating instructions**

-	With operating instructions
DN	Without operating instructions

# Twin-piston semi-rotary drives DRRD-8 ... 12

Technical data

FESTO

Function

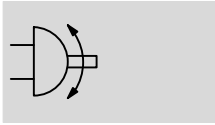

 www.festo.com



 Diameter  
8 ... 12 mm

 Torque  
0.2 ... 0.8 Nm

General technical data				
Size	8	10	12	
Design	Rack and pinion			
Mode of operation	Double-acting			
Pneumatic connection	M3	M3	M5	
Type of mounting	With through-hole Via female thread			
Swivel angle [°]	180 (→ page 10)			
Cushioning with fixed stop				
DRRD-...-P	Elastic cushioning at both ends			
DRRD-...-Y9	-		Linear shock absorber, self-adjusting at both ends	
DRRD-...-Y12	-		External linear shock absorber, self-adjusting at both ends	
Repetition accuracy [°]	≤ 0.03			
Axial run-out <sup>1)</sup> [mm]	≤ 0.02			
Max. axial load (static)				
Pulling [N]	260	260	330	
Pushing [N]	700	1100	1400	
Mounting position	Any			

1) Axial run-out in new condition

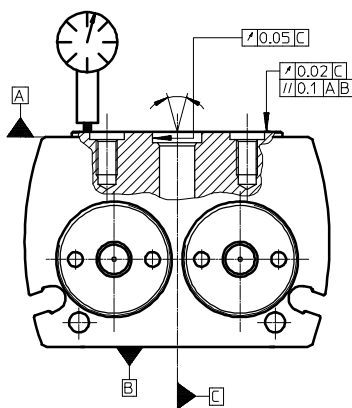



# Twin-piston semi-rotary drives DRRD-8 ... 12

Technical data

Operating and environmental conditions		
Operating medium		Compressed air to ISO 8573-1:2010 [7:4:4]
Note on operating/pilot medium		Lubricated operation possible (in which case lubricated operation will always be required)
Operating pressure		
DRRD-...-P	[bar]	3 ... 8
DRRD-...-Y9/-Y12	[bar]	2 ... 10
Ambient temperature	[°C]	-10 ... +60
Storage temperature	[°C]	-20 ... +60

Weight [g]			
Size	8	10	12
DRRD-...-P	155	245	380
DRRD-...-Y9	-	-	385
DRRD-...-Y12	-	-	500

Forces and torques				
Size	8	10	12	
Theoretical torque at 6 bar	[Nm]	0.2	0.4	0.8
Max. permissible mass moment of inertia				
DRRD-...-P	[kgcm <sup>2</sup> ]	15	20	80
DRRD-...-Y9	[kgcm <sup>2</sup> ]	-	-	300
DRRD-...-Y12	[kgcm <sup>2</sup> ]	-	-	300

 Note

If, in the end positions, a torque which exceeds 50% of the theoretical torque acts against the direction of rotation, no exact end position is guaranteed.

This can be avoided by using external shock absorbers (Y12) or a semi-rotary drive with double the torque.

## Materials

Sectional view

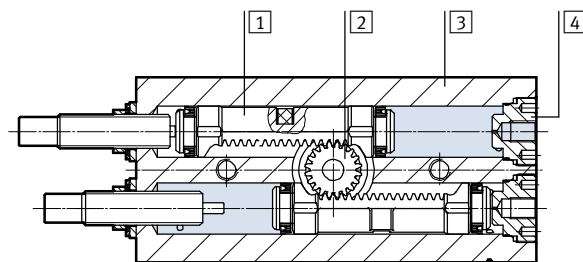

Semi-rotary drive	
1	Piston Copper base alloy
2	Flanged shaft High-alloy stainless steel
3	Housing Wrought aluminium alloy, hard-anodised
4	Port plug High-alloy stainless steel
	Seals NBR
	Piston seal TPE-U(PU)
	Note on materials RoHS compliant Contains paint-wetting impairment substances

# Twin-piston semi-rotary drives DRRD-8 ... 12

Technical data

## Swivel angle

Fundamentally, the following applies:

Swivel angle  $\alpha \geq$  cushioning angle  $\beta$

Swivel angle  $\alpha = 180^\circ + \Delta\alpha_{\text{clockwise}} + \Delta\alpha_{\text{anti-clockwise}}$

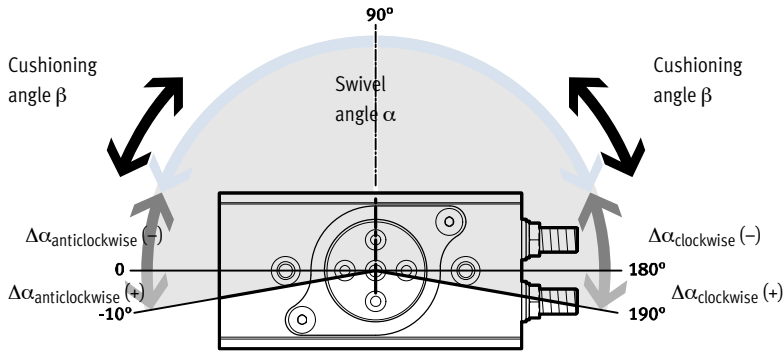

Size		8	10	12
Swivel angle $\alpha$	[°]	180		
Min. swivel angle $\alpha$ <sup>1)</sup>				
DRRD-...-P	[°]	38	37	32
DRRD-...-Y9	[°]	-	-	48
DRRD-...-Y12	[°]	-	-	20
Max. swivel angle $\alpha$				
DRRD-...	[°]	200		
DRRD-...-Y12	[°]	-	-	192
Swivel angle adjustment $\alpha$ per side (infinitely adjustable)				
DRRD-...-P	[°]	-100 ... +10		
DRRD-...-Y9	[°]	$\geq -100$ ... +10		
DRRD-...-Y12	[°]	-	-	-92 ... +6
Cushioning angle $\beta$				
DRRD-...-P	[°]	38	37	32
DRRD-...-Y9	[°]	-	-	48
DRRD-...-Y12	[°]	-	-	10

1) It is possible to set smaller swivel angles. However, this reduces the cushioning energy.

## Swivel angle adjustment

Clockwise direction of rotation:

- Swivel angle decreases

Anticlockwise direction of rotation:

- Swivel angle increases

The swivel angle is adjusted via the cushioning components using an Allen key. Any reduction in the swivel angle should preferably be evenly split between the two end positions.

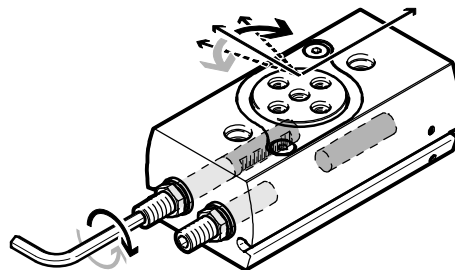

# Twin-piston semi-rotary drives DRRD-8 ... 12

Technical data

**Max. permissible mass moment of inertia J at the flanged shaft as a function of swivel time t (at room temperature and an operating pressure of 6 bar)**

Size 8 with cushioning P

Swivel angle 90°/180°

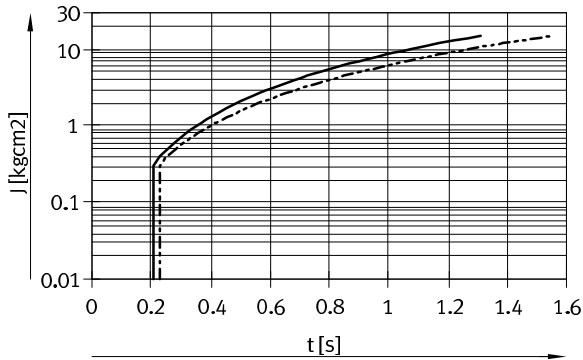

— DRRD-8-...P (90°)      Ranges → 0 ... 15 kgcm<sup>2</sup>  
 - - - DRRD-8-...P (180°)      Ranges → 0 ... 15 kgcm<sup>2</sup>

Size 10 with cushioning P

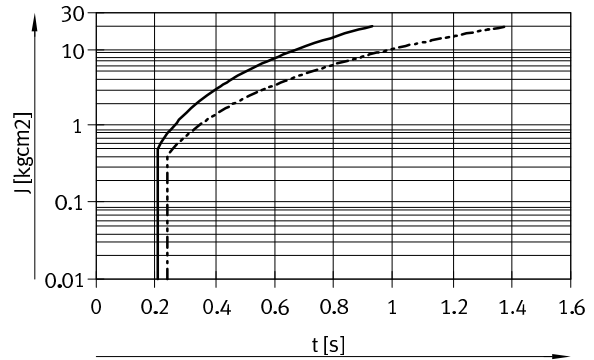

— DRRD-10-...P (90°)      Ranges → 0 ... 20 kgcm<sup>2</sup>  
 - - - DRRD-10-...P (180°)      Ranges → 0 ... 20 kgcm<sup>2</sup>

Size 12 with cushioning P/Y9

Swivel angle 90°

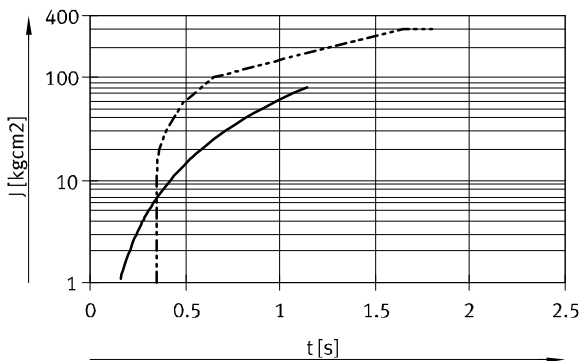

— DRRD-12-...-P (90°)      Ranges → 0 ... 80 kgcm<sup>2</sup>  
 - - - DRRD-12-...-Y9 (90°)      Ranges → 0 ... 300 kgcm<sup>2</sup>

Swivel angle 180°

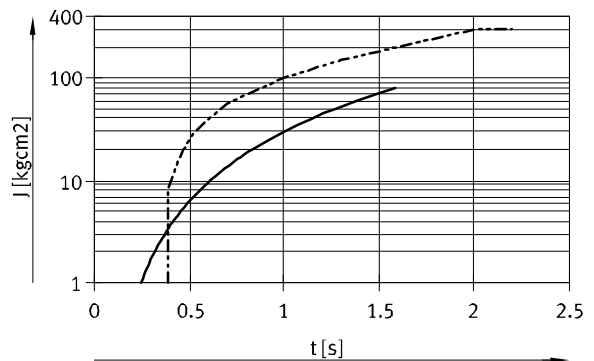

— DRRD-12-...-P (180°)      Ranges → 0 ... 80 kgcm<sup>2</sup>  
 - - - DRRD-12-...-Y9 (180°)      Ranges → 0 ... 300 kgcm<sup>2</sup>

Size 12 with cushioning Y12

Swivel angle 90°/180°

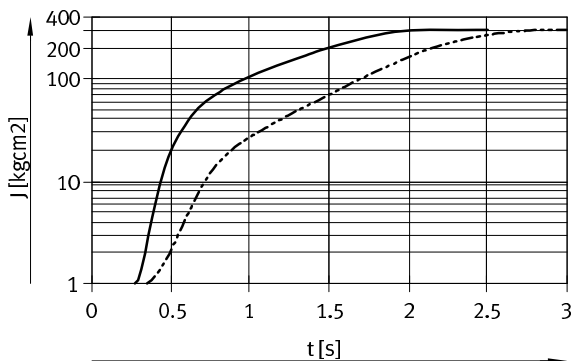

— DRRD-12-...-Y12 (90°)      Ranges → 1 ... 300 kgcm<sup>2</sup>  
 - - - DRRD-12-...-Y12 (180°)      Ranges → 1 ... 300 kgcm<sup>2</sup>

# Twin-piston semi-rotary drives DRRD-8 ... 12

Technical data

## Max. load capacity at the flanged shaft

The zero point for dimension z is always the flange level of the basic drive, independently of the mounting parts (flange assembly).

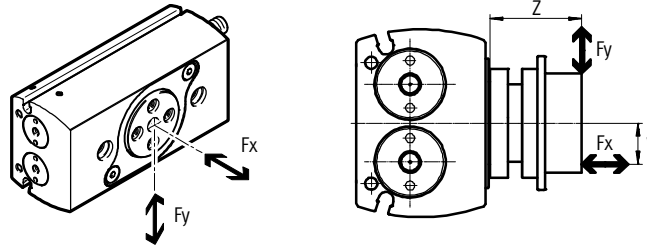

The following equation applies to combined loads (axial and radial):

$$\frac{F_{y(z)}}{F_{y, \max. (z)}} + \frac{F_{x(y)}}{F_{x, \max. (y)}} \leq 1$$

## Dynamic values

Max. radial force  $F_y$  as a function of distance z

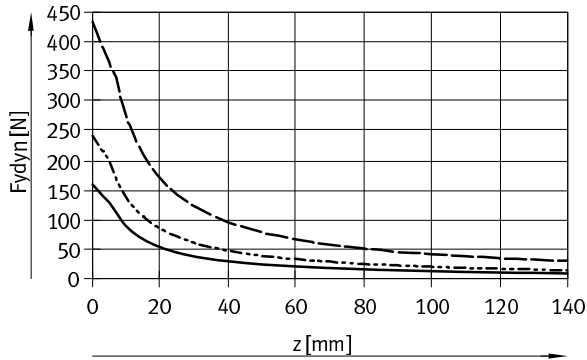

- DRRD-8
- - - DRRD-10
- · - DRRD-12

Max. axial force  $F_x$  as a function of distance y

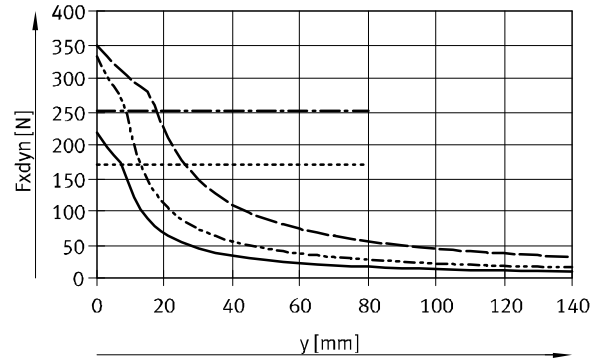

- - - Tensile force limit DRRD-8/10
- · - Tensile force limit DRRD-12

## Static values

Max. radial force  $F_y$  as a function of distance z

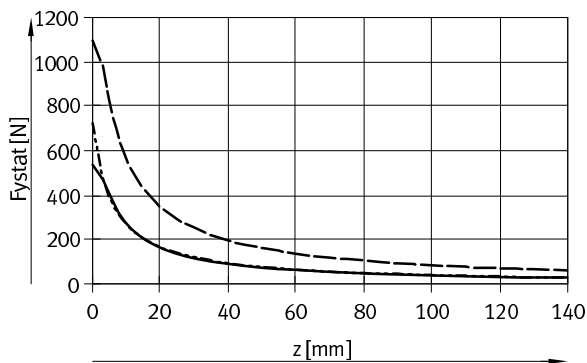

- DRRD-8
- - - DRRD-10
- · - DRRD-12

Max. axial force  $F_x$  as a function of distance y

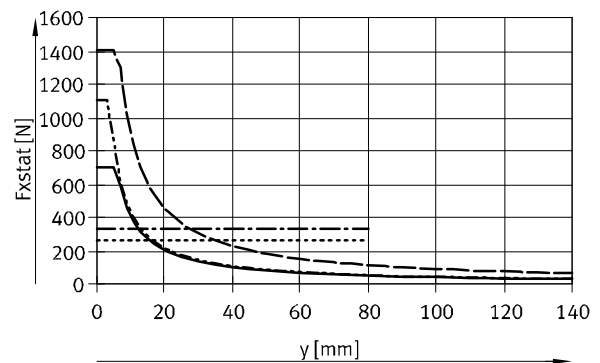

- - - Tensile force limit DRRD-8/10
- · - Tensile force limit DRRD-12

# Twin-piston semi-rotary drives DRRD-8 ... 12

Technical data

## Max. load capacity on drive shaft (DARF-Q11)

Max. radial forces  $F_y$  / axial forces  $F_x$  / bending moment  $M$

- For the radial forces  $F_y$ , the limits of the flanged shaft → page 12 and max. bending moment of the drive shaft apply → table below.
- The bending moment represents the load limit of the drive shaft and must not be exceeded.
- The zero point for dimension  $z$  is always the flange level of the basic drive, independently of the mounting parts (flange assembly).
- The axial force represents an additional load.

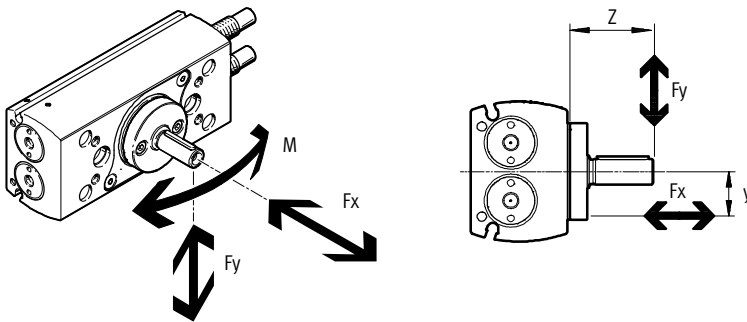

Size		12
Axial force $F_x$	[N]	170
Bending moment $M$	[Nm]	5.44

# Twin-piston semi-rotary drives DRRD-8 ... 12

Technical data

FESTO

## Dimensions

Download CAD data → [www.festo.com](http://www.festo.com)

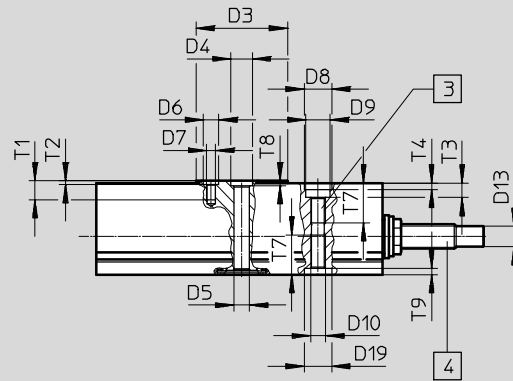
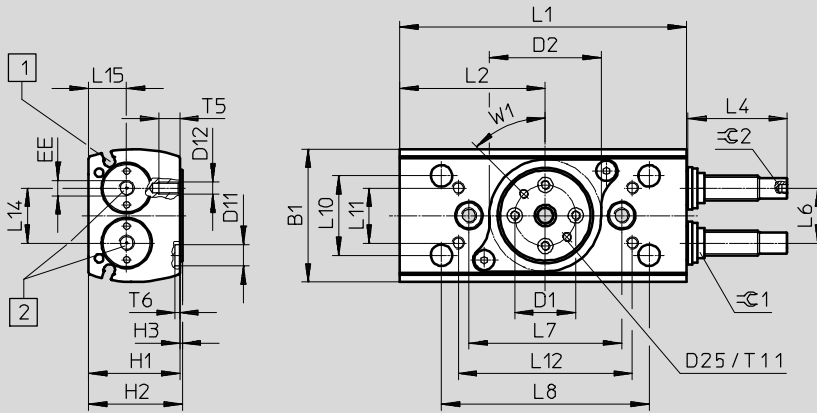

DRRD-8/10

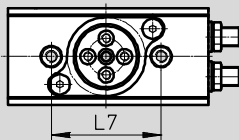

DRRD-...-P

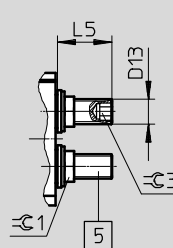

 Note

Illustrated position of the flanged shaft corresponds to the mid-position (swivel angle 90°).

Dimensions D25, T11 and W1 only for size 12.

- 1 Sensor slot for proximity sensor
- 2 Supply ports
- 3 Mounting thread
- 4 Shock absorber (DRRD-...-Y9)
- 5 Cushioning component (DRRD-...-P)

# Twin-piston semi-rotary drives DRRD-8 ... 12

Technical data

Size	B1 ±0.25	D1 ∅ ±0.025	D2 ∅ +0.1	D3 ∅	D4 ∅ H7	D5 ∅ ±0.1	D6 ∅ H7	D7	D8 ∅ H7	D9 ∅	D10
8	31.5	12	26	20.4	5	3	5	M3	7	6	M4
10	38	15	32	24	5	3	5	M3	7	6	M4
12	43.5	20	37	30	7	5	5	M3	9	8	M5

Size	D11 ∅ H7	D12	D13	D19 ∅ H7	D25	H1 +0.4	H2 ±0.2	H3 +0.2/-0.6	L1 ±0.1	L2 +0.1	L6
8	-	-	M6x0.5	7	-	24.5	25.25	0.75	65.6	32.2	13 <sub>-0.1</sub>
10	-	-	M6x0.5	7	-	27.5	28.25	0.75	74	38.3	15.2 <sub>-0.1</sub>
12	7	M4	M8x1	9	M3	30	30.75	0.75	93.9	47.7	18 <sup>+0.1</sup>

Size	L7 ±0.02	L8 ±0.2	L10 ±0.02	L11 ±0.15	L12 ±0.2	L14	L15 -0.1	T1	T2 +0.1	T3	T4 +0.4/-0.1
8	36	-	-	-	-	13	11.1	4.8	1.2	3.4	1.5
10	44	-	-	-	-	15.2	11.1	6.2	1.2	3.4	1.5
12	50	68	26	18	57	18	12.5	5.4	1.2	4.7	2.1

Size	T5	T6 +0.4/-0.1	T7	T8 +0.1	T9 +0.1	T11	EE	W1	≈C 1	≈C 2	≈C 3
8	-	-	10.5	1.2	1.6	-	M3	-	10	-	3
10	-	-	10	1.2	1.6	-	M3	-	10	-	3
12	7	1.6	13	1.6	2.1	5.5	M5	45°	10	2.5	5

Size	Dimension with 180° swivel angle		Swivel angle adjustment range		
	L4	L5	L4 min./max.	L5 min./max.	1 mm = ...°
8	-	11.1	-	-6.1/+0.8	16.4
10	-	12.6	-	-7.6/+1.2	13.64
12	28	17	-1.9/+1.9	-11/+1.8	9.6

# Twin-piston semi-rotary drives DRRD-8 ... 12

Technical data

Dimensions – Variants

Download CAD data → [www.festo.com](http://www.festo.com)

Y12 – With external shock absorber

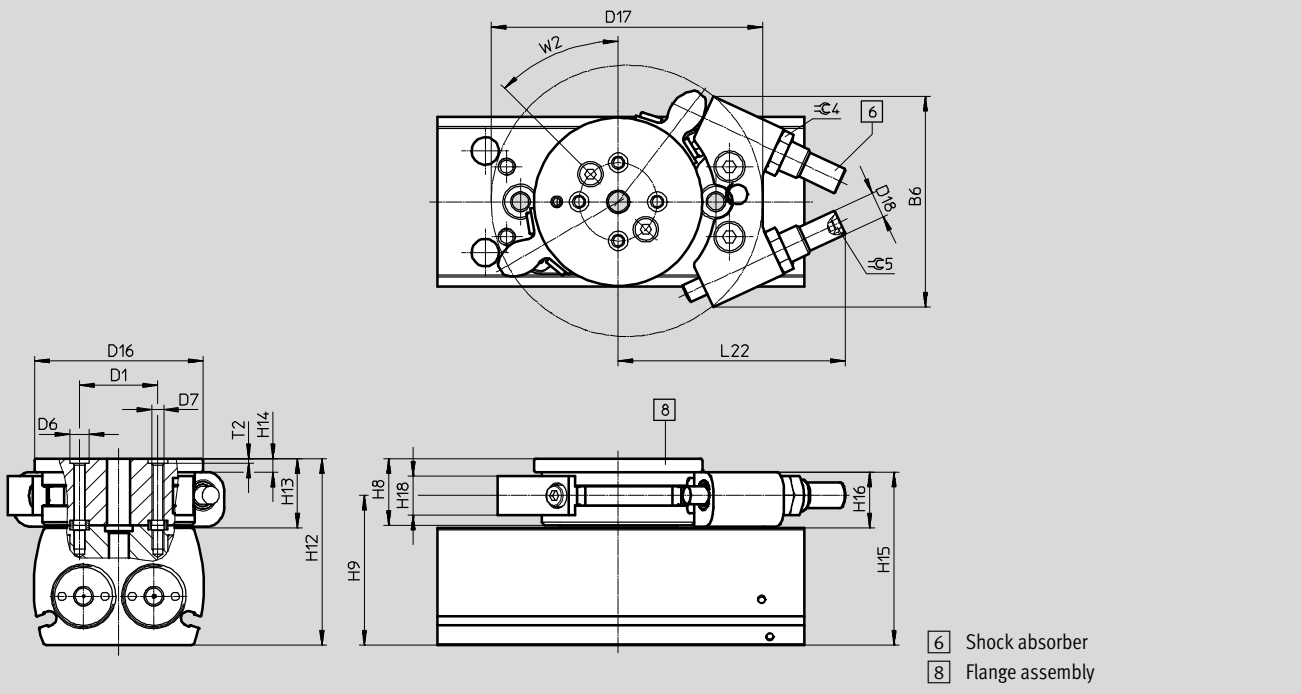

Size	B6	D1	D6	D7	D16	D17	D18	H8	H9	H12
	±0.2	∅ ±0.025	∅ H7	M3	∅ 43	69.4	M8x1	±0.1	38.25	±0.3
12	54	20	5	M3	43	69.4	M8x1	17	38.25	47.75

Size	H13	H14	H15	H16	H18	L22	T2	W2	∠ 4	∠ 5
						Max.	+0.1			
12	17.75	3.5	44	14	10	58.2	1.2	45°	10	2.5



# Twin-piston semi-rotary drives DRRD-8 ... 12

Ordering data

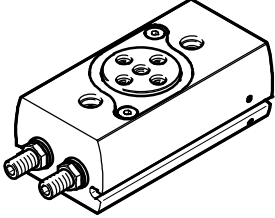
Ordering data – Stock items				
DRRD	Size	Swivel angle [°]	Part No.	Type
	P – Elastic cushioning rings/pads at both ends			
	8	180	2223060	DRRD-8-180-FH-PA
	10		2350968	DRRD-10-180-FH-PA
	12		2282067	DRRD-12-180-FH-PA
	Y9 – Linear shock absorber, self-adjusting at both ends			
	12	180	2399248	DRRD-12-180-FH-Y9A

Ordering table – Modular product system				
Size	12	Condi-tions	Code	Entry code
<b>M</b> Part no.	574398			
Function	Semi-rotary drive		<b>DRRD</b>	DRRD
Size	12		<b>-12</b>	-12
Nominal swivel angle	180°		<b>-180</b>	-180
Output shaft	Flanged shaft, hollow		<b>-FH</b>	-FH
Cushioning	Elastic cushioning rings/pads at both ends		<b>-P</b>	
	Linear shock absorber, self-adjusting at both ends		<b>-Y9</b>	
	Linear shock absorber, self-adjusting at both ends, external		<b>-Y12</b>	
Position sensing	Via proximity sensor		<b>A</b>	A
<b>O</b> Operating instructions	With operating instructions			
	Without operating instructions		<b>-DN</b>	

Transfer order code

# Twin-piston semi-rotary drives DRRD-16 ... 63

Peripherals overview

FESTO

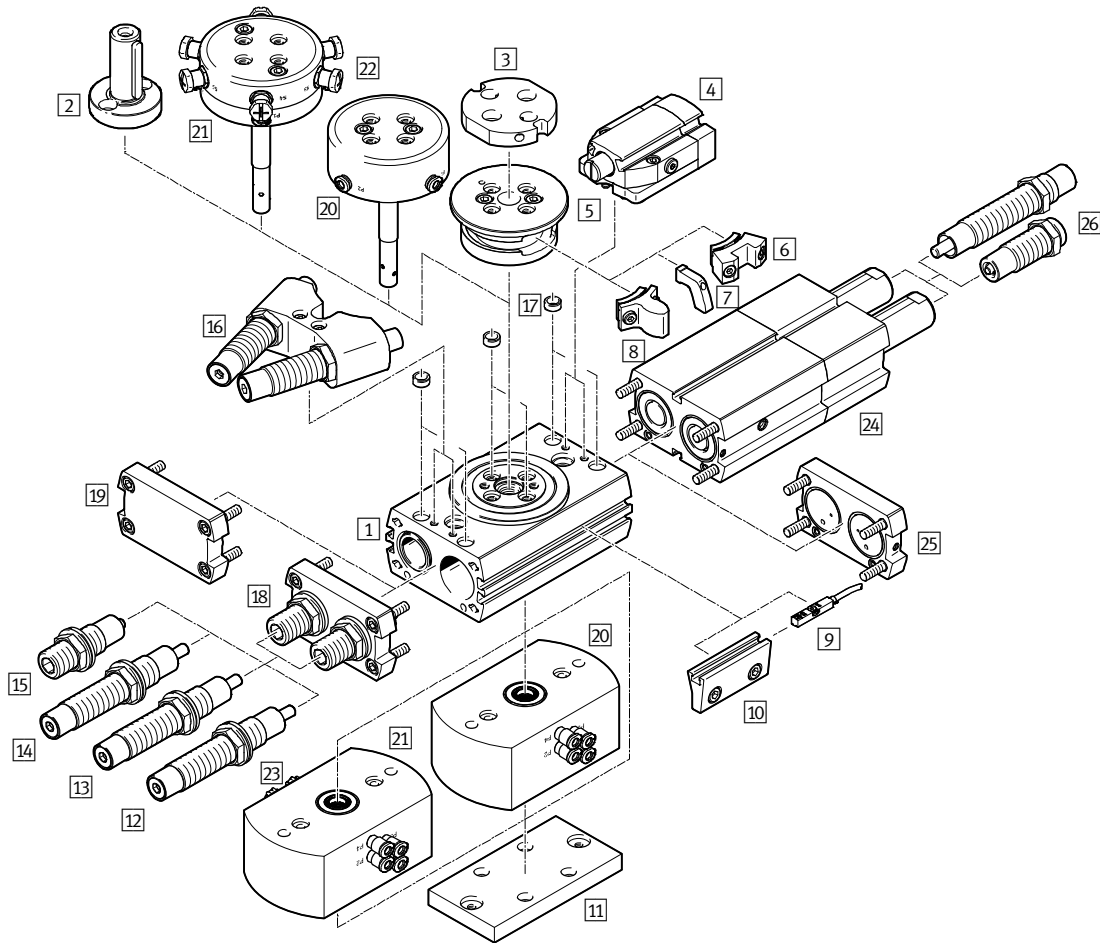

Variants, mounting components and accessories		Size								→ Page/ Internet
		16	20	25	32	35	40	50	63	
[1]	Semi-rotary drive DRRD	Double-acting								20
[2]	Drive shaft DARF-Q11	<ul style="list-style-type: none"> <li>The interface corresponds with that of semi-rotary drive DRQD</li> <li>The drive shaft should only be mounted directly onto the flanged shaft</li> <li>Suitable for ATEX</li> </ul>								56
[3]	Adapter kit DHAA	<ul style="list-style-type: none"> <li>Connecting plate between semi-rotary drive and gripper</li> <li>Included in the scope of delivery: 2 centring sleeves and screws</li> </ul>								gripper
[4]	End-position locking E1 (clamping unit DADL-...-EL as an accessory)	<ul style="list-style-type: none"> <li>Mechanical lock in the end positions to prevent unwanted movement when unpressurised</li> <li>Included in the scope of delivery: [4], [5], 2x [6]</li> </ul>								57
[5]	Flange assembly	Required to mount components [6], [7] and [8]								57
[6]	Clamping component (type: DADL-EC)	Secures the semi-rotary drive DRRD when cylinder [4] is advanced								59
[7]	Switch lug DASI-Q11-...-SL	For sensing the piston position using e.g. inductive proximity sensors SIES-8M → page 61, in conjunction with a sensor bracket [10]								59

# Twin-piston semi-rotary drives DRRD-16 ... 63

Peripherals overview

Variants, mounting components and accessories										
	Description	Size								→ Page/ Internet
		16	20	25	32	35	40	50	63	
8	Stop element	Serves as an end stop in combination with external shock absorbers (Y12)								55
9	Proximity sensor SMT/SME-8	For sensing the piston position								60
	Position sensor SMAT-8M	Analogue positional feedback from 0 ... 10 V possible								62
10	Sensor mounting R (sensing kit DASI-...-KT as an accessory)	<ul style="list-style-type: none"> <li>For sensing the piston position using e.g. inductive proximity sensors SIES-8M → page 61</li> <li>Included in the scope of delivery: [5], 2x [7], 2x [10]</li> </ul>								58
11	Adapter kit DHAA	Connecting plate between semi-rotary drive and drive								adapter
12	Shock absorber Y9	Linear shock absorber, self-adjusting at both ends								55
13	Shock absorber, hard Y10	Linear shock absorber, self-adjusting at both ends, hard								55
14	Shock absorber, soft Y14	Linear shock absorber, self-adjusting at both ends, soft								55
15	Shock absorber P	Elastic cushioning elements with metal end position, both ends								55
16	Shock absorber, external Y12	<ul style="list-style-type: none"> <li>Linear shock absorber, self-adjusting at both ends, external</li> <li>Included in the scope of delivery: [5], 2x [8], [16]</li> </ul>								55
17	Centring sleeve ZBH	For centring attachment (2 pieces included in the scope of delivery of the drive)								59
18	End cap	In conjunction with elastic cushioning element P or shock absorber Y9, Y10, Y14								-
19	End cap	In combination with external shock absorber Y12								-
20	Pneumatic energy throughfeed	Enables the quick and easy pneumatic supply of parts connected to the flange (e.g. gripper)								37
21	Pneumatic/electric energy throughfeed	Enables the quick and easy pneumatic/electrical supply of parts connected to the flange (e.g. gripper)								37
22	Connecting cable NEBU	From the energy throughfeed to the proximity sensor								63
23	Connecting cable NEBU	From the energy throughfeed to the controller								63
24	Intermediate position	Possible at 90°								40
25	Connection cap	For the supply ports								-
26	Shock absorber	The cushioning for the intermediate position corresponds to the cushioning for the basic drive. Except in the case of Y12 when shock absorbers Y9 are used								59
-	One-way flow control valves GRLA	To set the swivel speed								64

# Twin-piston semi-rotary drives DRRD-16 ... 63

Type codes

DRRD - [ ] - 180 - FH [ ] - [ ]

Product type	
Double-acting	
DRRD	Semi-rotary drive

Size	
------	--

Nominal swivel angle	
180	180°

Output shaft	
FH	Flanged shaft, hollow

Energy throughfeed	
-	None
P2	Pneumatic, 2 ducts
P2E2	Pneumatic, 2 ducts; electric, 2 signals
P4	Pneumatic, 4 ducts
P4E6	Pneumatic, 4 ducts; electric, 6 signals
P8	Pneumatic, 8 ducts
P8E8	Pneumatic, 8 ducts; electric, 8 signals

Cushioning	
P	Elastic cushioning at both ends
Y9	Linear shock absorber, self-adjusting at both ends, internal
Y10	Linear shock absorber, self-adjusting at both ends, hard, internal
Y12	Linear shock absorber, self-adjusting at both ends, external
Y14	Linear shock absorber, self-adjusting at both ends, soft, internal

Position sensing	
A	Via proximity sensor

# Twin-piston semi-rotary drives DRRD-16 ... 63

Type code

-	[ ]	-	[ ]	-	[ ]	-	[ ]	-	[ ]	-	[ ]
<b>EU certification</b>											
-	None										
EX4	II 2GD										
<b>Intermediate position</b>											
-	Without										
PS1	1 intermediate position										
<b>End-position locking</b>											
-	Without										
E1	At both ends										
<b>Sensor mounting, external</b>											
-	Without										
R	Mounting rail for proximity sensor										
<b>Version</b>											
-	Standard										
SG	Splash-proof design										
<b>Operating instructions</b>											
-	With operating instructions										
DN	Without operating instructions										

# Twin-piston semi-rotary drives DRRD-16 ... 63

Technical data

Function

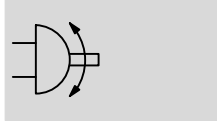

 www.festo.com



 Diameter  
16 ... 63 mm

 Torque  
1.6 ... 112 Nm

General technical data									
Size	16	20	25	32	35	40	50	63	
Design	Rack and pinion								
Mode of operation	Double-acting								
Pneumatic connection									
DRRD-...	M5			G1/8			G1/4	G3/8	
DRRD-...-PS1	M5						G1/8	-	
Type of mounting									
With through-hole									
Via female thread									
Swivel angle									
DRRD-...	[°]	180 (→ page 25)							
DRRD-...-PS1	[°]	90 ±10°							-
Cushioning with fixed stop									
DRRD-...-P	Elastic cushioning rings/plates at both ends							-	
DRRD-...-Y9	Linear shock absorber, self-adjusting at both ends								
DRRD-...-Y10 <sup>1)</sup>	-	Linear shock absorber, self-adjusting at both ends, hard			-	Linear shock absorber, self-adjusting at both ends, hard			
DRRD-...-Y12	Linear shock absorber, self-adjusting at both ends, external								
DRRD-...-Y14 <sup>1)</sup>	Linear shock absorber, self-adjusting at both ends, soft							-	
Repeat accuracy									
DRRD-...	[°]	< 0.05						≤0.03	
DRRD-...-PS1									
Approached from one end	[°]	0.1							-
Approached from both ends	[°]	0.7							-
Axial run-out <sup>2)</sup>	[mm]	< 0.05							
Max. axial load (static)	[N]	1500	2400	2400	3750	6100	6100	9000	11000
Mounting position	Any								

1) Not in combination with intermediate position DRRD-...-PS1

## 2) Axial run-out in new condition

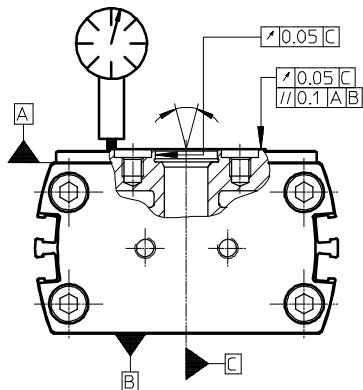

# Twin-piston semi-rotary drives DRRD-16 ... 63

Technical data

Operating and environmental conditions		
Operating medium	Compressed air to ISO 8573-1:2010 [7:4:4]	
Note on operating/pilot medium	Lubricated operation possible (in which case lubricated operation will always be required)	
Operating pressure		
DRRD-...		
DRRD-...-P	[bar]	3 ... 8
DRRD-...-Y9/-Y10/-Y12/-Y14	[bar]	2 ... 10
DRRD-...-PS1		
DRRD-...-P	[bar]	4 ... 8
DRRD-...-Y9/-Y12	[bar]	2 ... 10
Ambient temperature	[°C]	-10 ... +60
Storage temperature	[°C]	-20 ... +60
Degree of protection based on EN 60529		
DRRD-...-SG	IP65	

ATEX <sup>1)</sup>	
ATEX category for gas	II 2G
Type of (ignition) protection for gas	c T4
ATEX category for dust	II 2D
Type of (ignition) protection for dust	c T120°C
Explosion-proof ambient temperature	-10°C ≤ Ta ≤ +60°C
CE marking (see declaration of conformity)	To EU Explosion Protection Directive (ATEX)

1) Note the ATEX certification of the accessories.

Weight [g]								
Size	16	20	25	32	35	40	50	63
Basic drive with cushioning								
DRRD-...-P	640	839	1349	2815	4510	6070	-	-
DRRD-...-Y9/-Y10/-Y14	650	883	1358	2976	4784	6424	11300	19100
DRRD-...-Y12	757	1132	1705	3760	5425	7160	12450	22400
Energy throughfeed (additional)								
DRRD-...-P	320	350	710	920	1090	1470	1950	2250
DRRD-...-P...E...	460	480	720	900	880	1770	2330	2610
Intermediate position (additional)								
DRRD-...-P	502	701	1078	2304	-	-	-	-
DRRD-...-Y9	511	720	1130	2450	3940	4380	8270	-
End-position locking (additional)								
DRRD-...-E1	166	382	370	600	900	900	1610	2380
Sensor mounting, external (additional)								
DRRD-...-R	110	192	192	366	485	485	810	1390

# Twin-piston semi-rotary drives DRRD-16 ... 63

Technical data

Forces and torques									
Size		16	20	25	32	35	40	50	63
Theoretical torque at 6 bar	[Nm]	1.6	2.4	5.1	10.1	15.8	24.1	53	112
Max. permissible mass moment of inertia									
Rotation from end position to end position									
DRRD-...-P	[kgcm <sup>2</sup> ]	175	400	900	1500	2500	6700	–	–
DRRD-...-Y9	[kgcm <sup>2</sup> ]	700	1250	1500	26000	15000	23000	40000	40000
DRRD-...-Y10	[kgcm <sup>2</sup> ]	–	–	5500	–	45000	67000	200000	420000
DRRD-...-Y12	[kgcm <sup>2</sup> ]	900	1500	5500	26000	45000	67000	200000	420000
DRRD-...-Y14	[kgcm <sup>2</sup> ]	100	150	100	2000	2000	23000	–	–
Rotation with intermediate position									
DRRD-...-P	[kgcm <sup>2</sup> ]	150	300	400	500	–	–	–	–
DRRD-...-Y9	[kgcm <sup>2</sup> ]	500	900	1500	8000	15000	23000	40000	–
DRRD-...-Y12	[kgcm <sup>2</sup> ]	500	900	1500	8000	15000	23000	40000	–

 Note  
 If, in the end positions, a torque which exceeds 50% of the theoretical torque acts against the direction of rotation, no exact end position is guaranteed.  
 This can be avoided by using external shock absorbers (Y12) or a semi-rotary drive with double the torque.

 Note  
 The cushioning for the intermediate position corresponds to the cushioning for the basic drive. Except in the case of cushioning Y12 when shock absorbers Y9 are used.  
 In combination with cushioning P, the intermediate position is only available for sizes 16 ... 32.

## Materials

Sectional view

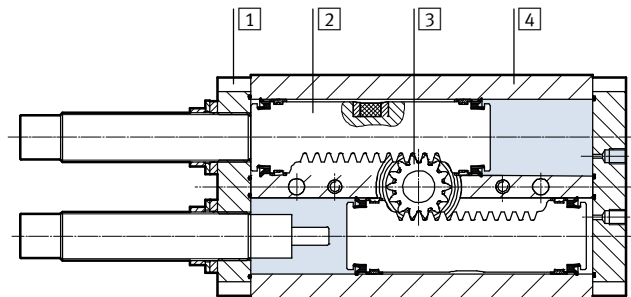

Semi-rotary drive	
1 End cap	Anodised wrought aluminium alloy
2 Piston	Stainless steel
3 Flanged shaft	Tempered steel
4 Housing	Wrought aluminium alloy, hard-anodised
Seals	NBR
Piston seal	TPE-U(PU)
Note on materials	RoHS compliant
	Contains paint-wetting impairment substances



# Twin-piston semi-rotary drives DRRD-16 ... 63

Technical data

## Swivel angle

Fundamentally, the following applies:

Swivel angle  $\alpha \geq$  cushioning angle  $\beta$

Swivel angle  $\alpha = 180^\circ + \Delta\alpha_{\text{clockwise}} + \Delta\alpha_{\text{anti-clockwise}}$

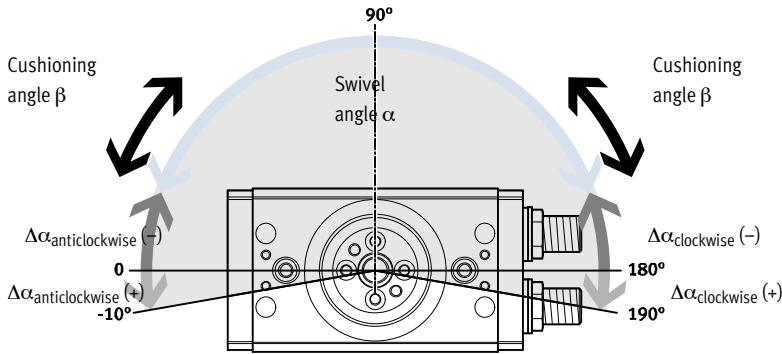

- - Note  
Illustrated position of the flanged shaft corresponds to the mid-position (swivel angle 90°).

Size	16	20	25	32	35	40	50	63	
Swivel angle $\alpha$	[°] 180								
Min. swivel angle $\alpha^1$									
DRRD-...-P	[°] 36	45	33	33	36	23	-	-	
DRRD-...-Y9/-Y10/-Y14	[°] 43	72	79	82	85	56	61	48	
DRRD-...-Y12	[°] 20	24	38	34	34	34	30	34	
DRRD-...-E1	[°] 60	60	60	55	57	57	62	55	
Max. swivel angle $\alpha^2$									
DRRD-...	[°] 200								
DRRD-...-Y12	[°] 192	194	190	190	193	193	186	190	
Swivel angle adjustment $\alpha$ per side (infinitely adjustable)									
DRRD-...-P	[°] -100 ... +10							-	-
DRRD-...-Y9/-Y10/-Y14	[°] $\geq$ -100 ... +10								
DRRD-...-Y12	[°] -94 ... +6	-85 ... +7	-88 ... +5	-93 ... +5	-86 ... +6.5		-86 ... +3	-91 ... +5	
Cushioning angle $\beta$									
DRRD-...-P	[°] 36	45	33	33	36	23	-	-	
DRRD-...-Y9/-Y10/-Y14	[°] 43	72	79	82	85	56	61	48	
DRRD-...-Y12	[°] 10	12	19	17	17	17	15	17	

1) It is possible to set smaller swivel angles. However, this reduces the cushioning energy.  
2) The max. swivel angle is reduced by approx. 10° in combination with the external sensor mounting

## Swivel angle adjustment

Clockwise direction of rotation:

- Swivel angle decreases

Anticlockwise direction of rotation:

- Swivel angle increases

The swivel angle is adjusted via the cushioning components using an Allen key. Any reduction in the swivel angle should preferably be evenly split between the two end positions.

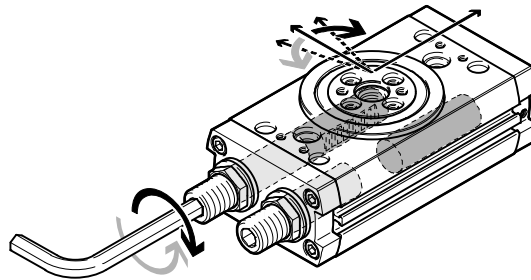

Swivel angle adjustment of the intermediate position → page 40

# Twin-piston semi-rotary drives DRRD-16 ... 63

Technical data

**Max. permissible mass moment of inertia J at the flanged shaft as a function of swivel time t (at room temperature and an operating pressure of 6 bar)**

Size 16 with cushioning P/Y9/Y14

Swivel angle 90°

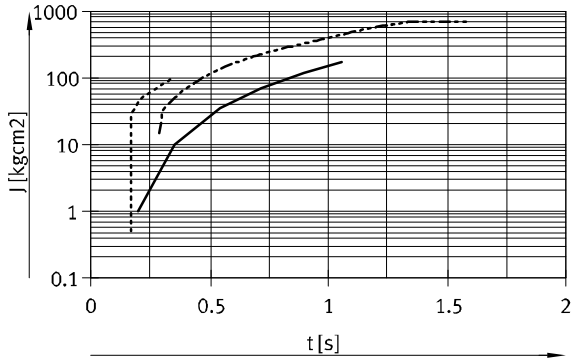

—	DRRD-16-...-P (90°)	Ranges	→ 1 ... 175 kgcm <sup>2</sup>
- - -	DRRD-16-...-Y9 (90°)		→ 15 ... 700 kgcm <sup>2</sup>
· · ·	DRRD-16-...-Y14 (90°)		→ 0.5 ... 100 kgcm <sup>2</sup>

Swivel angle 180°

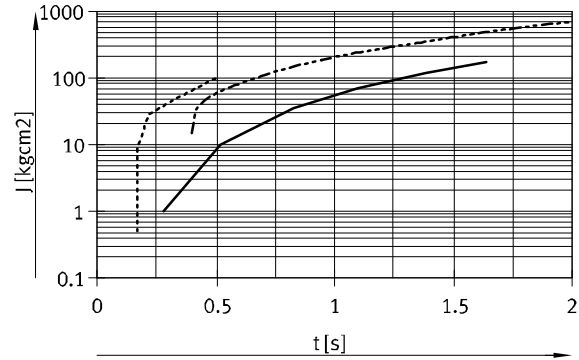

—	DRRD-16-...-P (180°)	Ranges	→ 1 ... 175 kgcm <sup>2</sup>
- - -	DRRD-16-...-Y9 (180°)		→ 15 ... 700 kgcm <sup>2</sup>
· · ·	DRRD-16-...-Y14 (180°)		→ 0.5 ... 100 kgcm <sup>2</sup>

Size 20 with cushioning P/Y9/Y14

Swivel angle 90°

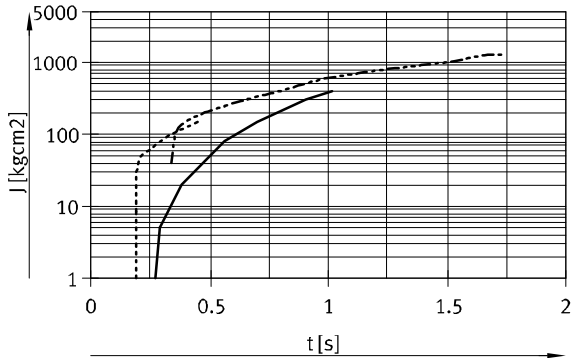

—	DRRD-20-...-P (90°)	Ranges	→ 1 ... 400 kgcm <sup>2</sup>
- - -	DRRD-20-...-Y9 (90°)		→ 40 ... 1250 kgcm <sup>2</sup>
· · ·	DRRD-20-...-Y14 (90°)		→ 1 ... 150 kgcm <sup>2</sup>

Swivel angle 180°

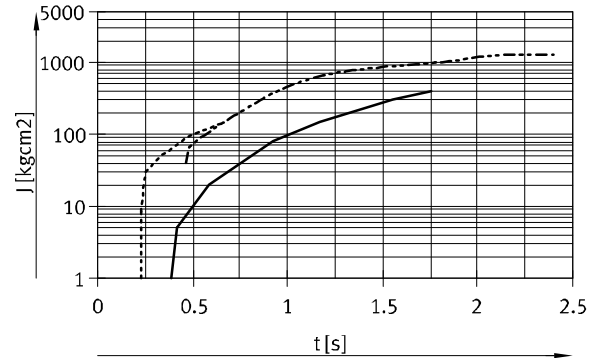

—	DRRD-20-...-P (180°)	Ranges	→ 1 ... 400 kgcm <sup>2</sup>
- - -	DRRD-20-...-Y9 (180°)		→ 40 ... 1250 kgcm <sup>2</sup>
· · ·	DRRD-20-...-Y14 (180°)		→ 1 ... 150 kgcm <sup>2</sup>

# Twin-piston semi-rotary drives DRRD-16 ... 63

Technical data

## Max. permissible mass moment of inertia J at the flanged shaft as a function of swivel time t (at room temperature and an operating pressure of 6 bar)

Size 25 with cushioning P/Y9/Y10/Y14

Swivel angle 90°

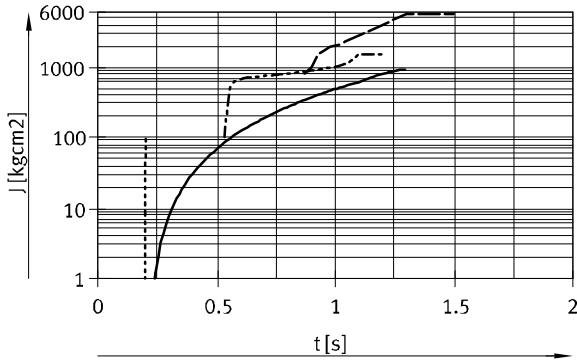

—	DRRD-25-...-P (90°)	Ranges	→ 1 ... 900 kgcm <sup>2</sup>
- - - - -	DRRD-25-...-Y9 (90°)		→ 100 ... 1500 kgcm <sup>2</sup>
- · - · -	DRRD-25-...-Y10 (90°)		→ 800 ... 5500 kgcm <sup>2</sup>
· · · · ·	DRRD-25-...-Y14 (90°)		→ 1 ... 100 kgcm <sup>2</sup>

Swivel angle 180°

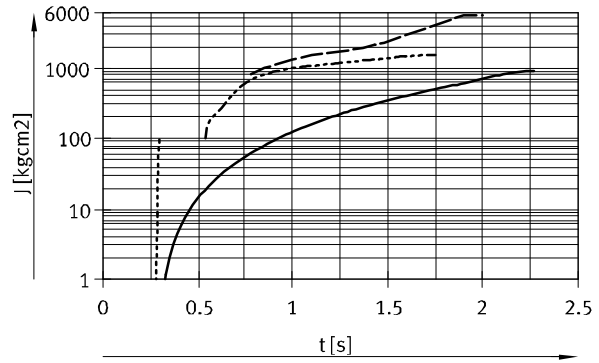

—	DRRD-25-...-P (180°)	Ranges	→ 1 ... 900 kgcm <sup>2</sup>
- - - - -	DRRD-25-...-Y9 (180°)		→ 100 ... 1500 kgcm <sup>2</sup>
- · - · -	DRRD-25-...-Y10 (180°)		→ 800 ... 5500 kgcm <sup>2</sup>
· · · · ·	DRRD-25-...-Y14 (180°)		→ 1 ... 100 kgcm <sup>2</sup>

Size 32 with cushioning P/Y9/Y14

Swivel angle 90°

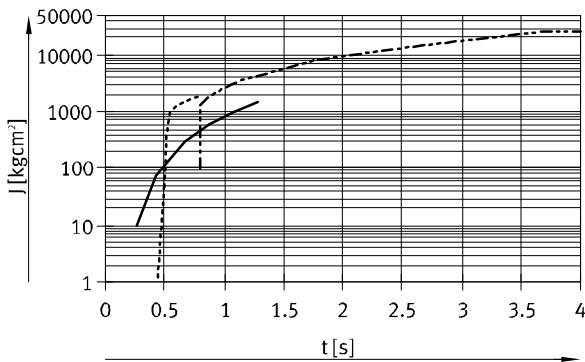

—	DRRD-32-...-P (90°)	Ranges	→ 10 ... 1500 kgcm <sup>2</sup>
- - - - -	DRRD-32-...-Y9 (90°)		→ 100 ... 26000 kgcm <sup>2</sup>
· · · · ·	DRRD-32-...-Y14 (90°)		→ 1 ... 2000 kgcm <sup>2</sup>

Swivel angle 180°

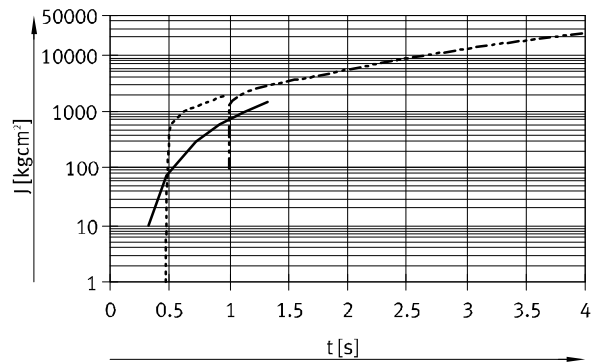

—	DRRD-32-...-P (180°)	Ranges	→ 10 ... 1500 kgcm <sup>2</sup>
- - - - -	DRRD-32-...-Y9 (180°)		→ 100 ... 26000 kgcm <sup>2</sup>
· · · · ·	DRRD-32-...-Y14 (180°)		→ 1 ... 2000 kgcm <sup>2</sup>

# Twin-piston semi-rotary drives DRRD-16 ... 63

Technical data

**Max. permissible mass moment of inertia J at the flanged shaft as a function of swivel time t (at room temperature and an operating pressure of 6 bar)**

Size 35 with cushioning P/Y9/Y10/Y14

Swivel angle 90°

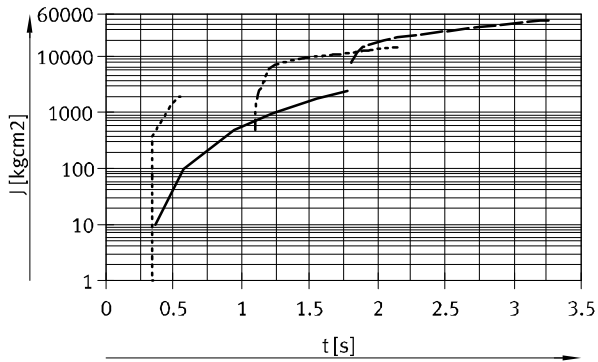

—	DRRD-35-...-P (90°)	Ranges	→ 10 ... 2500 kgcm <sup>2</sup>
- - - - -	DRRD-35-...-Y9 (90°)		→ 500 ... 15000 kgcm <sup>2</sup>
- · - · - ·	DRRD-35-...-Y10 (90°)		→ 8000 ... 45000 kgcm <sup>2</sup>
· · · · ·	DRRD-35-...-Y14 (90°)		→ 1 ... 2000 kgcm <sup>2</sup>

Swivel angle 180°

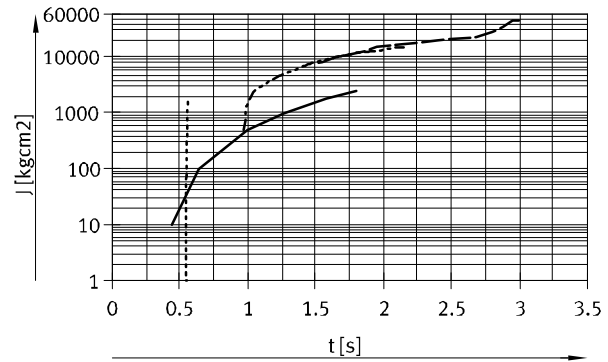

—	DRRD-35-...-P (180°)	Ranges	→ 10 ... 2500 kgcm <sup>2</sup>
- - - - -	DRRD-35-...-Y9 (180°)		→ 500 ... 15000 kgcm <sup>2</sup>
- · - · - ·	DRRD-35-...-Y10 (180°)		→ 8000 ... 45000 kgcm <sup>2</sup>
· · · · ·	DRRD-35-...-Y14 (180°)		→ 1 ... 2000 kgcm <sup>2</sup>

Size 40 with cushioning P/Y9/Y10/Y14

Swivel angle 90°

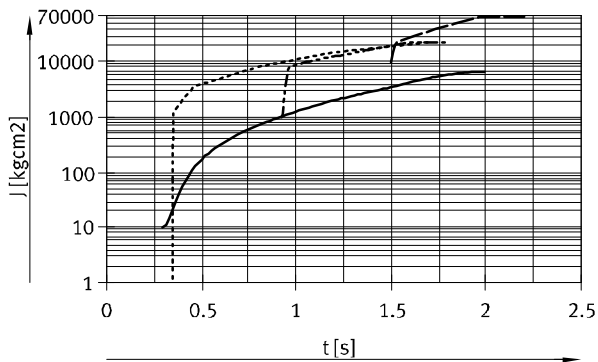

—	DRRD-40-...-P (90°)	Ranges	→ 10 ... 6700 kgcm <sup>2</sup>
- - - - -	DRRD-40-...-Y9 (90°)		→ 1000 ... 23000 kgcm <sup>2</sup>
- · - · - ·	DRRD-40-...-Y10 (90°)		→ 10000 ... 67000 kgcm <sup>2</sup>
· · · · ·	DRRD-40-...-Y14 (90°)		→ 1 ... 23000 kgcm <sup>2</sup>

Swivel angle 180°

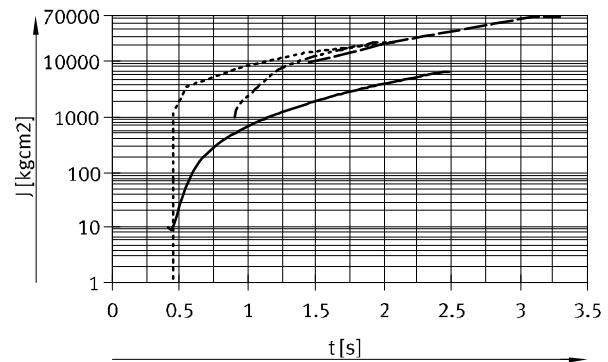

—	DRRD-40-...-P (180°)	Ranges	→ 10 ... 6700 kgcm <sup>2</sup>
- - - - -	DRRD-40-...-Y9 (180°)		→ 1000 ... 23000 kgcm <sup>2</sup>
- · - · - ·	DRRD-40-...-Y10 (180°)		→ 10000 ... 67000 kgcm <sup>2</sup>
· · · · ·	DRRD-40-...-Y14 (180°)		→ 1 ... 23000 kgcm <sup>2</sup>

# Twin-piston semi-rotary drives DRRD-16 ... 63

Technical data

## Max. permissible mass moment of inertia J at the flanged shaft as a function of swivel time t (at room temperature and an operating pressure of 6 bar)

Size 50 with cushioning Y9/Y10

Swivel angle 90°

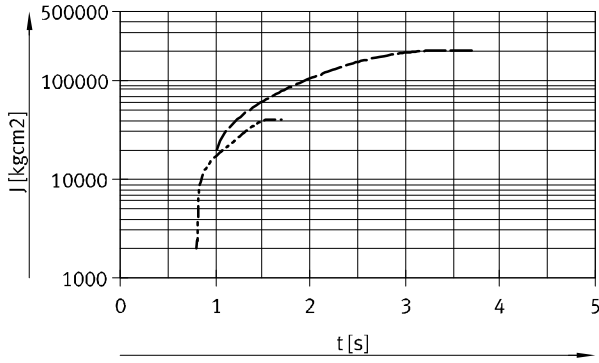

- - - - - DRRD-50-...-Y9 (90°)      Ranges → 2000 ... 40000 kgcm<sup>2</sup>  
 — — — — — DRRD-50-...-Y10 (90°)      Ranges → 20000 ... 200000 kgcm<sup>2</sup>

Swivel angle 180°

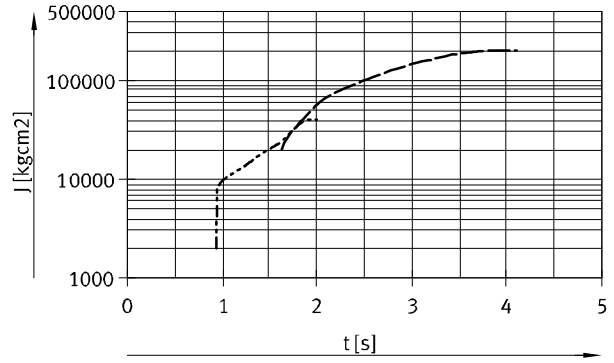

- - - - - DRRD-50-...-Y9 (180°)      Ranges → 2000 ... 40000 kgcm<sup>2</sup>  
 — — — — — DRRD-50-...-Y10 (180°)      Ranges → 20000 ... 200000 kgcm<sup>2</sup>

Size 63 with cushioning Y9/Y10

Swivel angle 90°

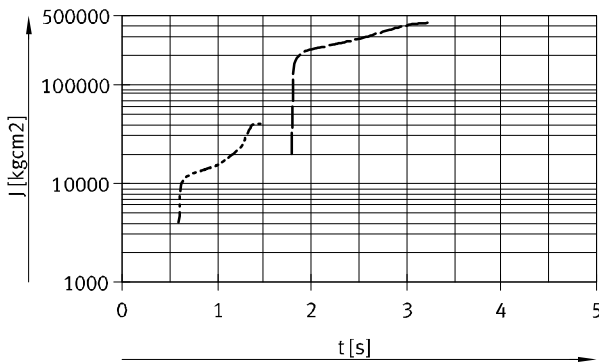

- - - - - DRRD-63-...-Y9 (90°)      Ranges → 4000 ... 40000 kgcm<sup>2</sup>  
 — — — — — DRRD-63-...-Y10 (90°)      Ranges → 20000 ... 420000 kgcm<sup>2</sup>

Swivel angle 180°

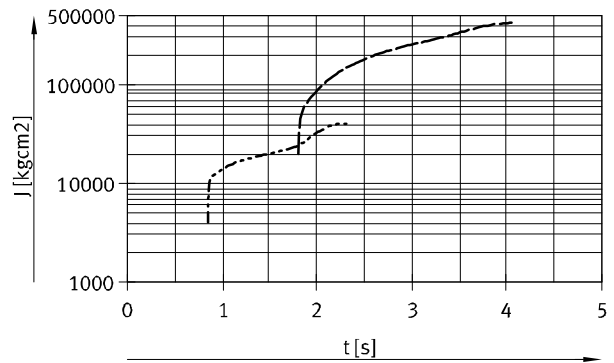

- - - - - DRRD-63-...-Y9 (180°)      Ranges → 4000 ... 40000 kgcm<sup>2</sup>  
 — — — — — DRRD-63-...-Y10 (180°)      Ranges → 20000 ... 420000 kgcm<sup>2</sup>

# Twin-piston semi-rotary drives DRRD-16 ... 63

Technical data

Max. permissible mass moment of inertia  $J$  at the flanged shaft as a function of swivel time  $t$   
(at room temperature and an operating pressure of 6 bar)

Size 16 with cushioning Y12

Size 20 with cushioning Y12

Swivel angle 90°/180°

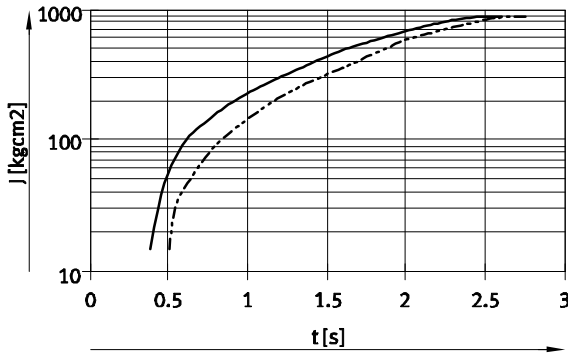

—	DRRD-16-...-Y12 (90°)	Ranges	→ 15 ... 900 kgcm <sup>2</sup>
- - -	DRRD-16-...-Y12 (180°)		→ 15 ... 900 kgcm <sup>2</sup>

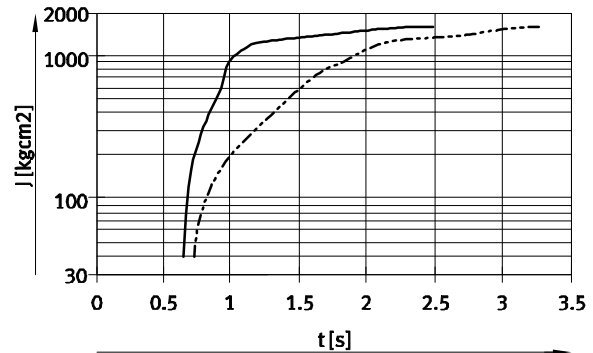

—	DRRD-20-...-Y12 (90°)	Ranges	→ 40 ... 1600 kgcm <sup>2</sup>
- - -	DRRD-20-...-Y12 (180°)		→ 40 ... 1600 kgcm <sup>2</sup>

Size 25 with cushioning Y12

Size 32 with cushioning Y12

Swivel angle 90°/180°

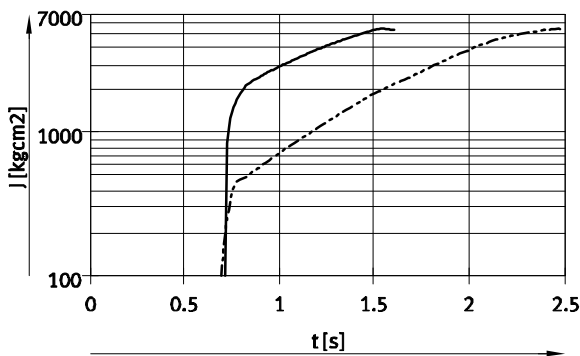

—	DRRD-25-...-Y12 (90°)	Ranges	→ 100 ... 5500 kgcm <sup>2</sup>
- - -	DRRD-25-...-Y12 (180°)		→ 100 ... 5500 kgcm <sup>2</sup>

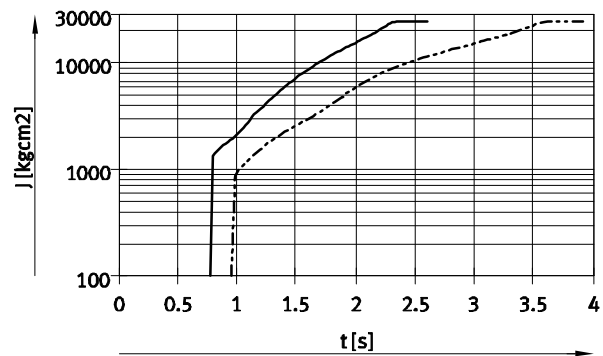

—	DRRD-32-...-Y12 (90°)	Ranges	→ 100 ... 26000 kgcm <sup>2</sup>
- - -	DRRD-32-...-Y12 (180°)		→ 100 ... 26000 kgcm <sup>2</sup>

# Twin-piston semi-rotary drives DRRD-16 ... 63

Technical data

Max. permissible mass moment of inertia  $J$  at the flanged shaft as a function of swivel time  $t$   
(at room temperature and an operating pressure of 6 bar)

Size 35 with cushioning Y12

Size 40 with cushioning Y12

Swivel angle 90°/180°

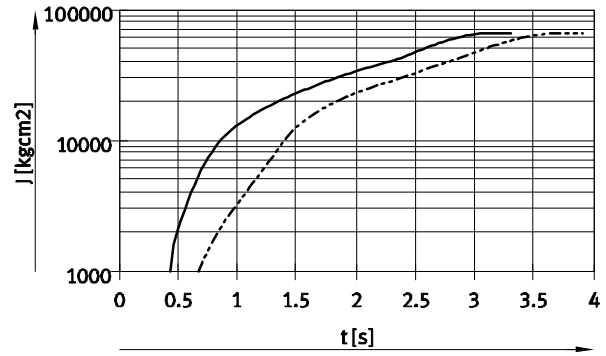
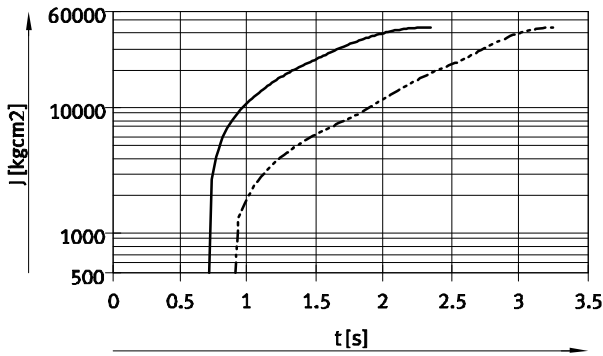

— DRRD-35-...-Y12 (90°)      Ranges → 500 ... 45000 kgcm<sup>2</sup>  
 - - - DRRD-35-...-Y12 (180°)      Ranges → 500 ... 45000 kgcm<sup>2</sup>

— DRRD-40-...-Y12 (90°)      Ranges → 1000 ... 67000 kgcm<sup>2</sup>  
 - - - DRRD-40-...-Y12 (180°)      Ranges → 1000 ... 67000 kgcm<sup>2</sup>

Size 50 with cushioning Y12

Size 63 with cushioning Y12

Swivel angle 90°/180°

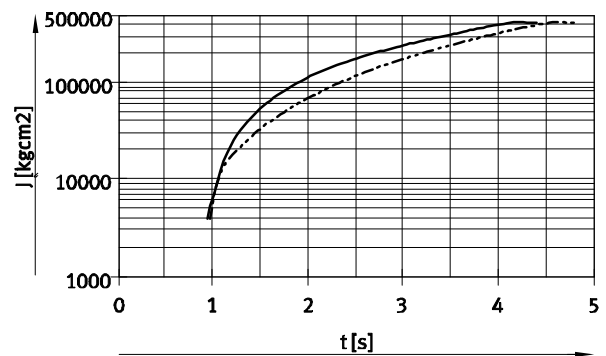
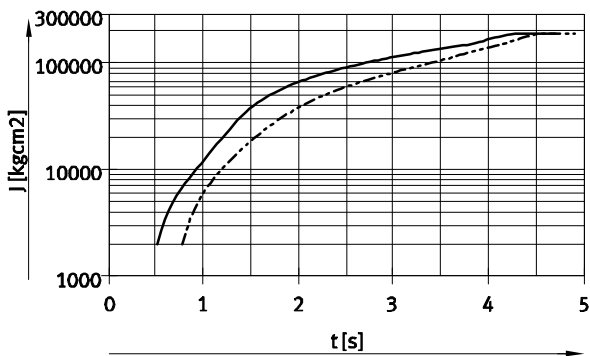

— DRRD-50-...-Y12 (90°)      Ranges → 2000 ... 200000 kgcm<sup>2</sup>  
 - - - DRRD-50-...-Y12 (180°)      Ranges → 2000 ... 200000 kgcm<sup>2</sup>

— DRRD-63-...-Y12 (90°)      Ranges → 4000 ... 420000 kgcm<sup>2</sup>  
 - - - DRRD-63-...-Y12 (180°)      Ranges → 4000 ... 420000 kgcm<sup>2</sup>

# Twin-piston semi-rotary drives DRRD-16 ... 63

Technical data

## Max. dynamic load capacity at the flanged shaft

The zero point for dimension Z is always the flange level of the basic drive, independently of the mounting parts (flange assembly).

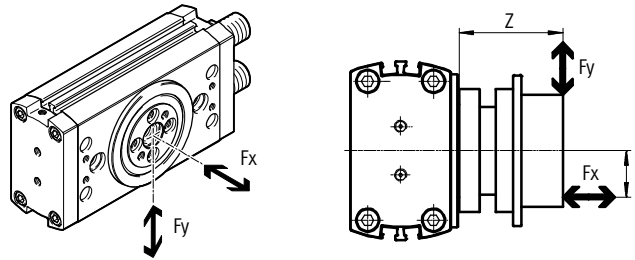

The following equation applies to combined loads (axial and radial):

$$\frac{F_{y(z)}}{F_{y, \max.(z)}} + \frac{F_{x(y)}}{F_{x, \max.(y)}} \leq 1$$

Max. dynamic radial force  $F_y$  as a function of distance z

Size 16/20

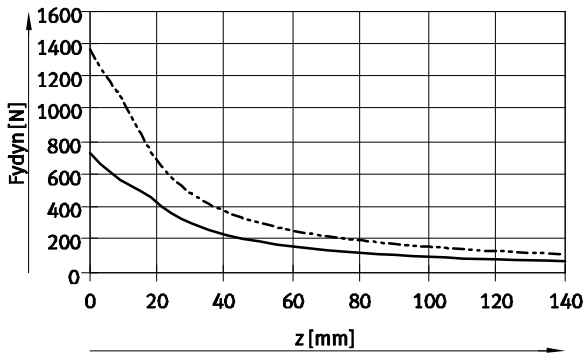

— DRRD-16  
- - - DRRD-20

Size 25/32

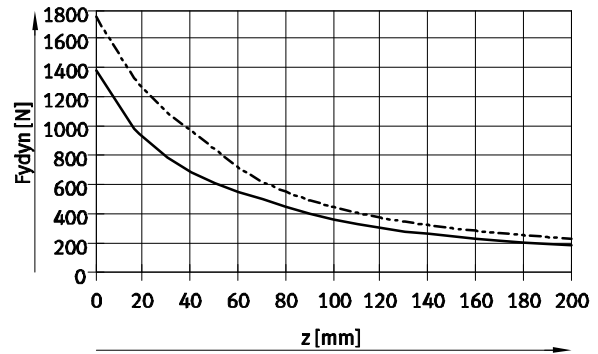

— DRRD-25  
- - - DRRD-32

Size 35/40

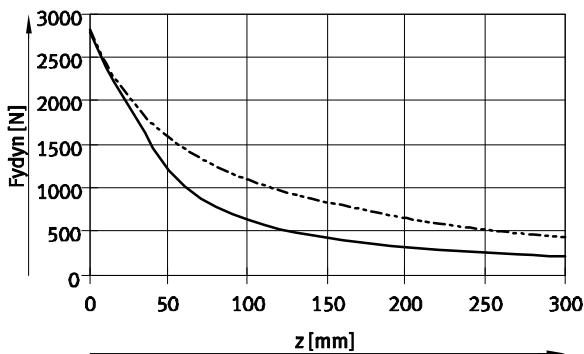

— DRRD-35  
- - - DRRD-40

Size 50/63

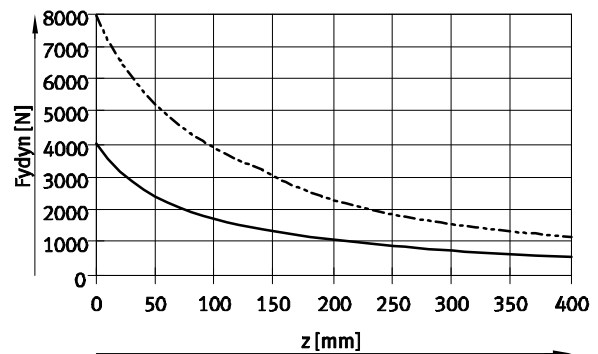

— DRRD-50  
- - - DRRD-63



# Twin-piston semi-rotary drives DRRD-16 ... 63

Technical data

## Max. dynamic load capacity at the flanged shaft

The zero point for dimension Z is always the flange level of the basic drive, independently of the mounting parts (flange assembly).

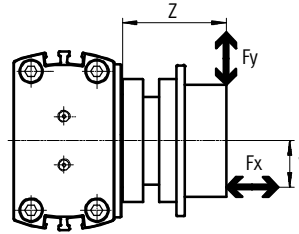
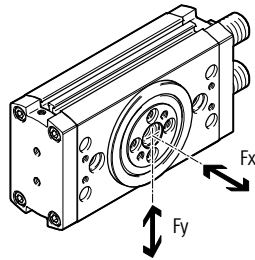

The following equation applies to combined loads (axial and radial):

$$\frac{F_{y(z)}}{F_{y, \max.(z)}} + \frac{F_{x(y)}}{F_{x, \max.(y)}} \leq 1$$

Max. dynamic axial force  $F_x$  as a function of distance y

Size 16/20

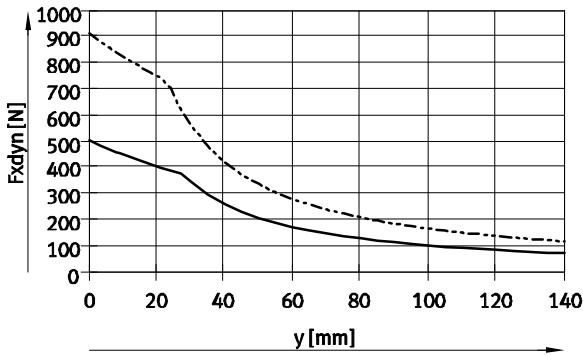

— DRRD-16  
- - - DRRD-20

Size 25/32

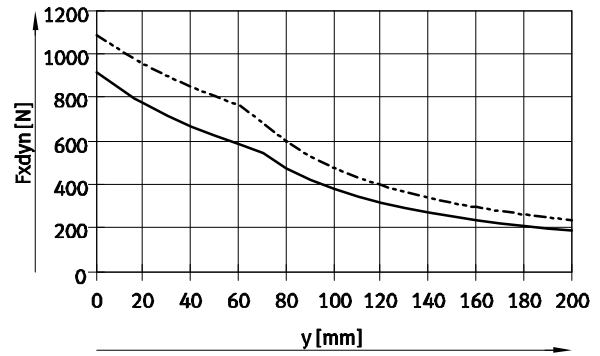

— DRRD-25  
- - - DRRD-32

Size 35/40

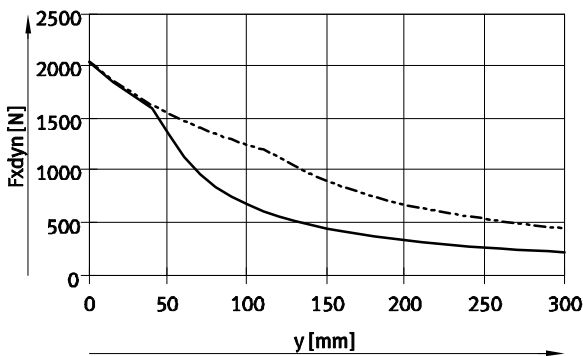

— DRRD-35  
- - - DRRD-40

Size 50/63

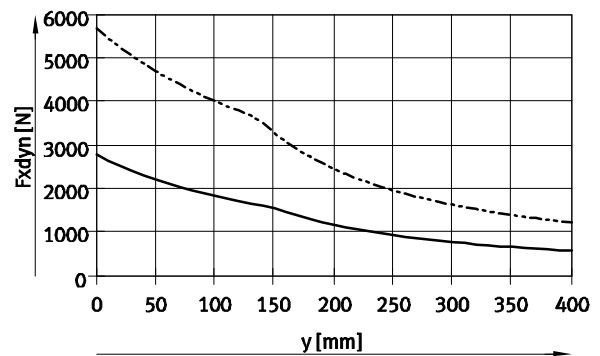

— DRRD-50  
- - - DRRD-63

# Twin-piston semi-rotary drives DRRD-16 ... 63

Technical data

## Max. static load capacity at the flanged shaft

The zero point for dimension Z is always the flange level of the basic drive, independently of the mounting parts (flange assembly).

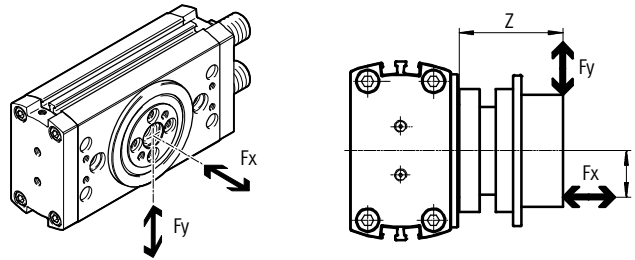

The following equation applies to combined loads (axial and radial):

$$\frac{F_y(z)}{F_{y, \max.}(z)} + \frac{F_x(y)}{F_{x, \max.}(y)} \leq 1$$

Max. static radial force  $F_y$  as a function of distance z

Size 16/20

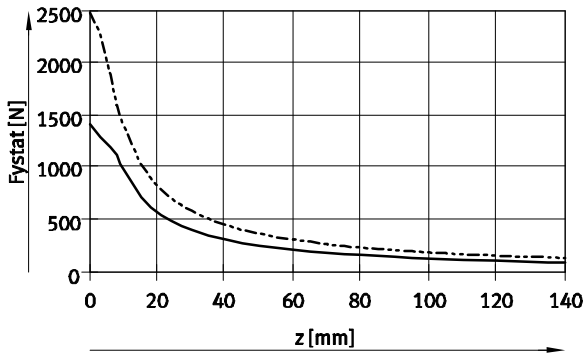

— DRRD-16  
- - - DRRD-20

Size 25/32

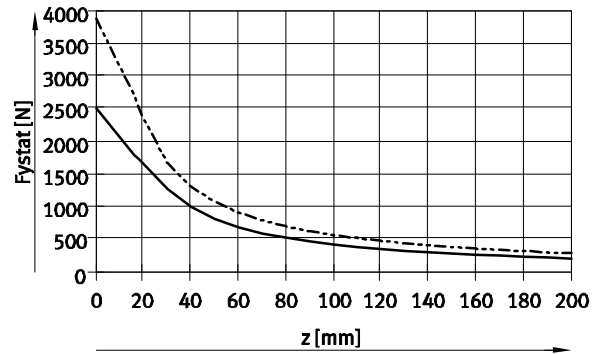

— DRRD-25  
- - - DRRD-32

Size 35/40

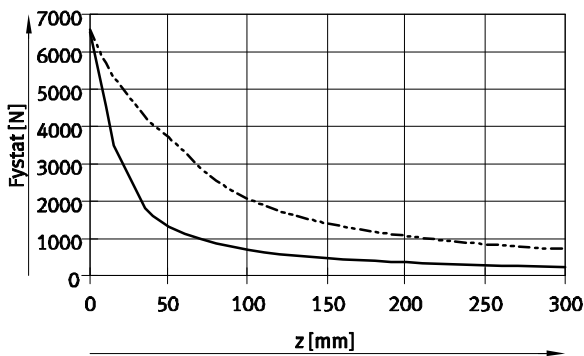

— DRRD-35  
- - - DRRD-40

Size 50/63

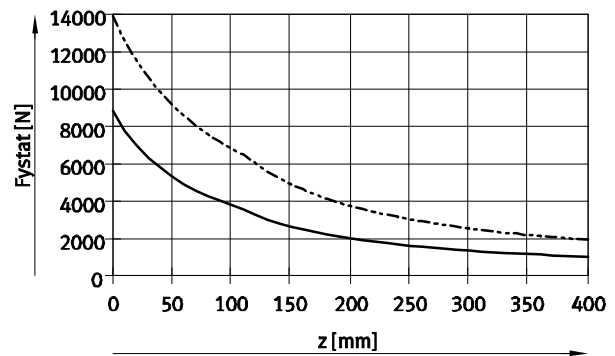

— DRRD-50  
- - - DRRD-63

# Twin-piston semi-rotary drives DRRD-16 ... 63

Technical data

## Max. static load capacity at the flanged shaft

The zero point for dimension Z is always the flange level of the basic drive, independently of the mounting parts (flange assembly).

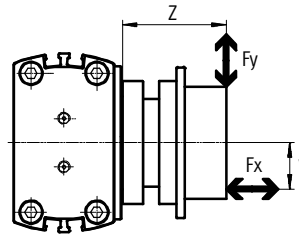
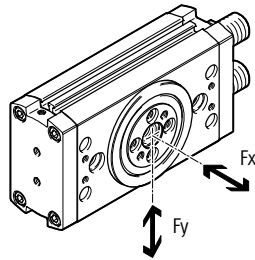

The following equation applies to combined loads (axial and radial):

$$\frac{F_{y(z)}}{F_{y, \max.(z)}} + \frac{F_{x(y)}}{F_{x, \max.(y)}} \leq 1$$

Max. static axial force  $F_x$  as a function of distance  $y$   
Size 16/20

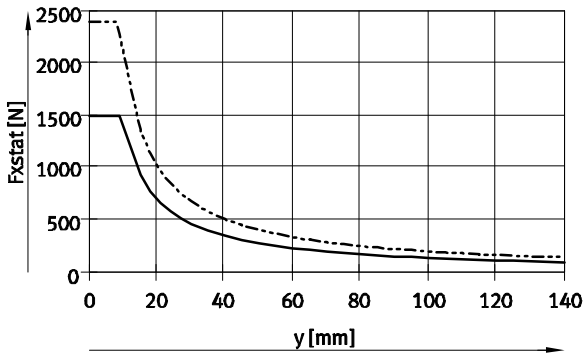

— DRRD-16  
- - - DRRD-20

Size 25/32

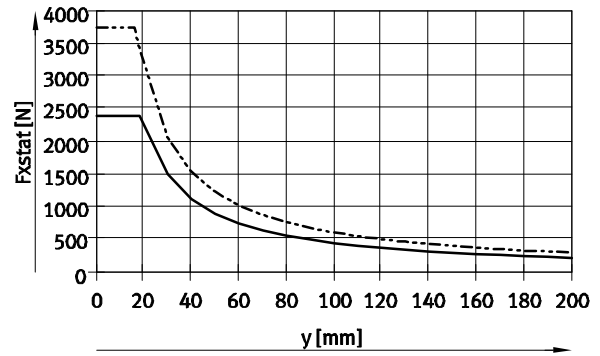

— DRRD-25  
- - - DRRD-32

Size 35/40

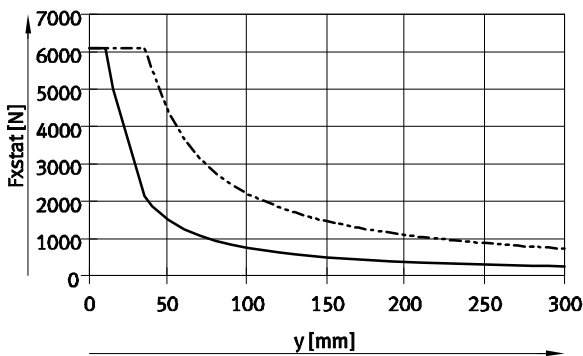

— DRRD-35  
- - - DRRD-40

Size 50/63

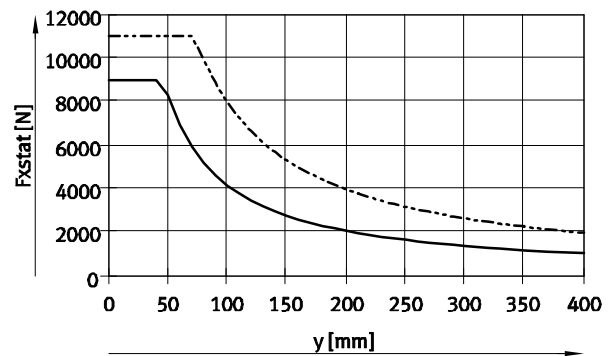

— DRRD-50  
- - - DRRD-63

# Twin-piston semi-rotary drives DRRD-16 ... 63

Technical data

### Max. load capacity on drive shaft (DARF-Q11)

Max. radial forces  $F_y$  / axial forces  $F_x$  / bending moment  $M$

- For the radial forces  $F_y$ , the limits of the flanged shaft → page 32 and max. bending moment of the drive shaft apply → table below.
- The bending moment represents the load limit of the drive shaft and must not be exceeded.
- The zero point for dimension  $z$  is always the flange level of the basic drive, independently of the mounting parts (flange assembly).
- The axial force represents an additional load.

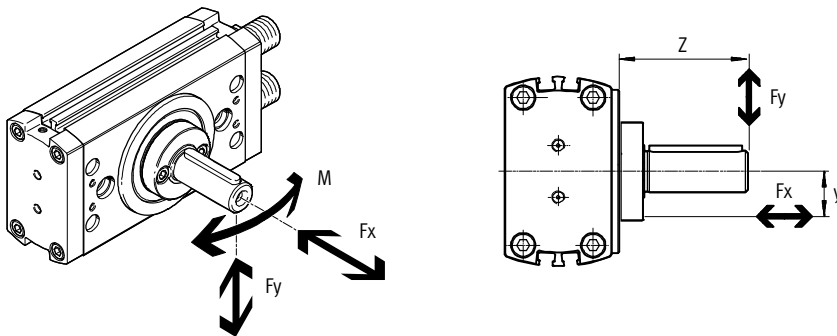

Size		16	20	25	32	35	40
Axial force $F_x$	[N]	625	625	625	900	900	2400
Bending moment $M$	[Nm]	13.5	14.4	34.4	63	63	84

# Twin-piston semi-rotary drives DRRD-16 ... 63

Technical data

Energy throughfeed  
DRRD-...-P...E...

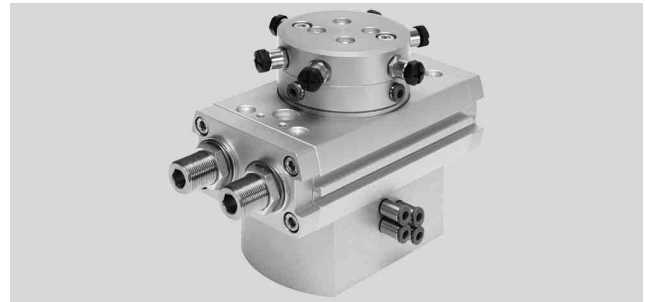

- |  |   |  |  |
|--|---|--|--|
| <b>Function</b>  | <b>Benefits</b>   |  |  |
| Electrical signals or compressed air can be transferred through the hollow shaft using the energy throughfeed. | <ul style="list-style-type: none"> <li>• Fast and easy supply of the parts connected to the flange (e.g. gripper)</li> <li>• Tubing and electrical cables are not damaged by the rotation</li> <li>• Two variants available:                             <ul style="list-style-type: none"> <li>– Pneumatic</li> <li>– Pneumatic and electrical</li> </ul> </li> <li>• Different number of connections depending on the size</li> </ul> |  |  |

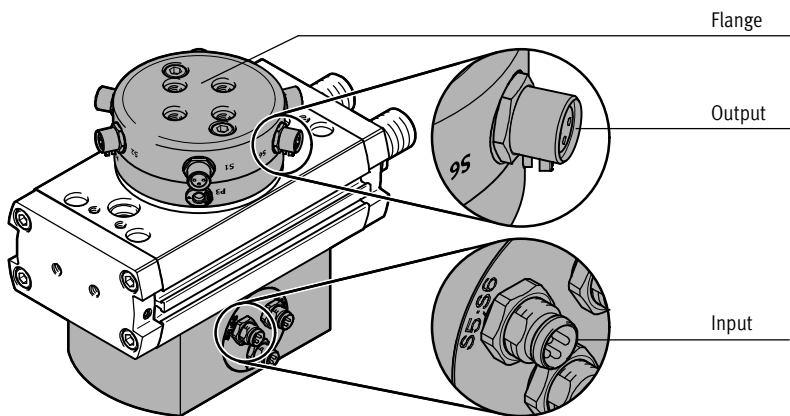

Note  
Only connecting cables with straight connectors can be used (→ page 63).

Technical data						
Size	16/20		25/32/35		40/50/63	
Variant	Pneumatic	Pneumatic/ electrical	Pneumatic	Pneumatic/ electrical	Pneumatic	Pneumatic/ electrical
Order code	P2	P2E2	P4	P4E6	P8	P8E8
<b>Pneumatic</b>						
Number of pneumatic ducts	2	2	4	4	8	8
Tubing O.D.	4					
Max. operating pressure [bar]	8					
Connection	M5					
Flow rate per duct [l/min.]	86				33	
<b>Electrical</b>						
Number of electric signals	–	2	–	6	–	8
Rated voltage [V DC]	–	30	–	30	–	30
Max. current <sup>1)</sup> [A]	1.5					
Connection	M8				M12	

1) The positive and negative lines of each electrical connection are linked. The combined maximum peak current for this common positive and negative line is also 1.5 A.

# Twin-piston semi-rotary drives DRRD-16 ... 63

Technical data

DRRD-...-P...E... – Energy throughfeed							
Pin allocation							
Size 16/20							
Input M8 plug				Output M8 socket			
Designation	Signals	Pin <sup>1)</sup>	Circuit diagram	Circuit diagram	Pin <sup>1)</sup>	Signals	Designation
S1	+ - Sig 1	1 3 4			1 3 4	+ - Sig 1	S1
S2	+ - Sig 2	1 3 4			1 3 4	+ - Sig 2	S2

1) Pin 1 (+) and Pin 3 (-) are connected to each other between plugs S1 and S2. Unused plugs and sockets should therefore be protected with the cover caps.

Pin allocation							
Sizes 25/32/35							
Input M8 plug				Output M8 socket			
Designation	Signals	Pin <sup>1)</sup>	Circuit diagram	Circuit diagram	Pin <sup>1)</sup>	Signals	Designation
S1;S2	+ Sig 2 - Sig 1	1 2 3 4			1 3 4	+ - Sig 1	S1
					1 3 4	+ - Sig 2	S2
S3;S4	+ Sig 4 - Sig 3	1 2 3 4			1 3 4	+ - Sig 3	S3
					1 3 4	+ - Sig 4	S4
S5;S6	+ Sig 6 - Sig 5	1 2 3 4			1 3 4	+ - Sig 5	S5
					1 3 4	+ - Sig 6	S6

1) Pin 1 (+) and Pin 3 (-) are connected to each other between plugs S1 ... S6. Unused plugs and sockets should therefore be protected with the cover caps.

# Twin-piston semi-rotary drives DRRD-16 ... 63

Technical data

DRRD-...-P...E... – Energy throughfeed							
Size 40/50/63							
Input M12 plug				Output M12 socket			
Designation	Signals	Pin <sup>1)</sup>	Circuit diagram	Circuit diagram	Pin <sup>1)</sup>	Signals	Designation
S1;S2	+ Sig 2 - Sig 1	1 2 3 4			1 2 3 4	+ Sig 2 - Sig 1	S1;S2
S3;S4	+ Sig 4 - Sig 3	1 2 3 4			1 2 3 4	+ Sig 4 - Sig 3	S3;S4
S5;S6	+ Sig 6 - Sig 5	1 2 3 4			1 2 3 4	+ Sig 6 - Sig 5	S5;S6
S7;S8	+ Sig 8 - Sig 7	1 2 3 4			1 2 3 4	+ Sig 8 - Sig 7	S7;S8

1) Pin 1 (+) and Pin 3 (-) are connected to each other between plugs S1 ... S8. Unused plugs and sockets should therefore be protected with the cover caps.

# Twin-piston semi-rotary drives DRRD-16 ... 63

Technical data

FESTO

## Intermediate position DRRD-...-PS1



### Function

The intermediate-position module enables an additional position to be set, at half of the nominal rotation angle (90°).

A piston with two screwed-in guide

systems is supplied with compressed air and moves the racks of the unpressurised semi-rotary drive until both pistons rest on the plungers positioned in the guide systems and are

held in this position. The movement is cushioned using a shock absorber.

For further movement to the end position, the semi-rotary drive is

pressurised with compressed air. The piston of the basic drive thus moves the entire intermediate-position piston back into its initial position.

### Feature

- Setting range: 90° ±10°
- Cushioning variants: P, Y9
- Can be approached and travelled through from both end positions
- Position sensing of the intermediate position possible

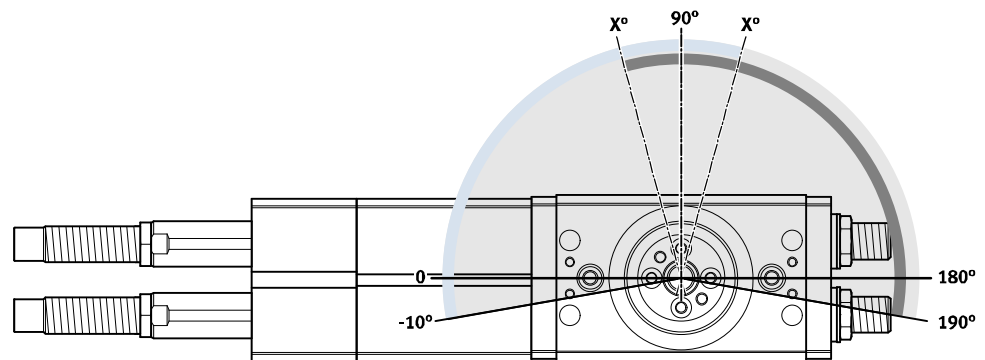

### Setting the swivel speed

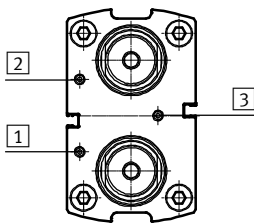

Semi-rotary module and intermediate-position module must only be operated with controlled air flow. The throttles should be connected as close as possible to the semi-rotary drive (e.g. one-way flow control valve GRLA-...) → page 64.

In the event of pressure failure, the payload may hit an end position in an uncontrolled manner. In order to prevent this, piloted check valves HGL or an air reservoir VZS are recommended → page 64.

The following movements are adjusted using the supply ports **1** and **2**: end position → intermediate position.

Both directions can be adjusted separately from each other.

The following movement is set via supply port **3**.

Intermediate position → end position

Both directions are set simultaneously.



# Twin-piston semi-rotary drive DRRD-16 ... 63

Technical data

FESTO

## DRRD-...-PS1 – Intermediate position

### Swivel angle adjustment

By pushing the shock absorber as far as the stop, the flanged shaft of the semi-rotary drive rotates into the intermediate position.

In delivered state, the intermediate position is set to 90°. By screwing in

or unscrewing the shock absorbers, the swivel angle can be adjusted by  $\pm 10^\circ$ .

If the setting dimension  $X_{max}$  is exceeded, the shock absorber can no longer completely cushion the

movement.

If the setting dimension  $X_{min}$  is not reached, the shock absorber not only cushions the intermediate position, but also the end position of the semi-rotary drive.

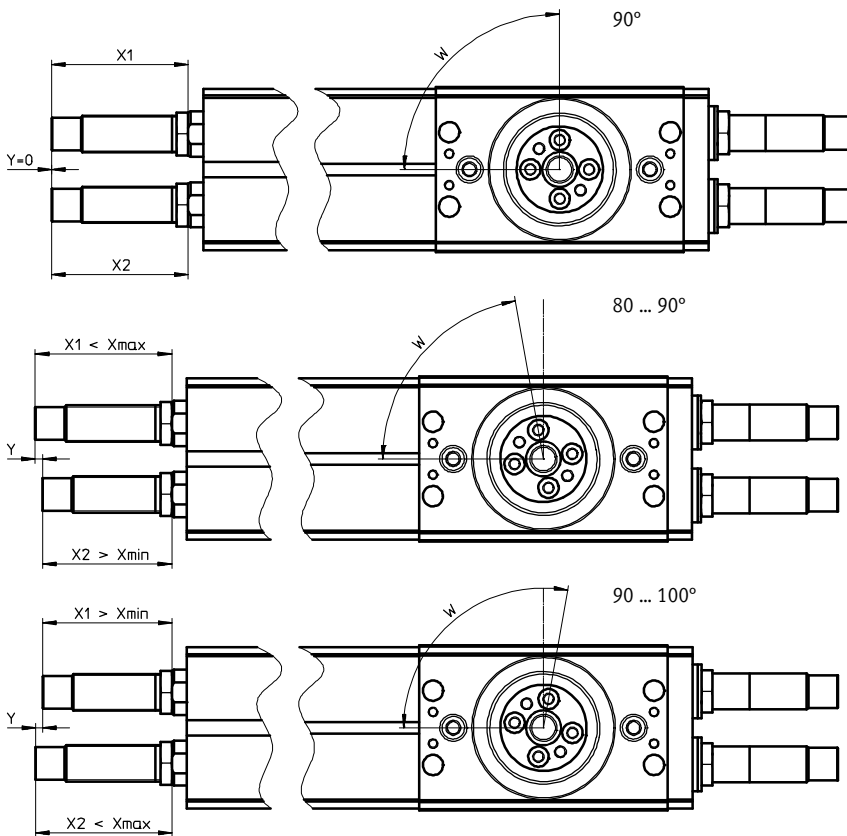

Size		16	20	25	32	35	40	50
Setting dimension X								
DRRD-...-P								
$X_{min}$	[mm]	7.7	14.9	14.2	12.5	–	–	–
$X_{max}$	[mm]	101	17.8	20.6	23.2	–	–	–
DRRD-...-Y9								
$X_{min}$	[mm]	29.6	41.8	56.9	70.3	88.6	86.7	114
$X_{max}$	[mm]	32	44.5	60.4	78.5	96.2	92.7	128
Dimension Y for 10° swivel angle change	[mm]	2.3	2.4	3.2	3.7	3.7	5.6	8

# Twin-piston semi-rotary drives DRRD-16 ... 63

Technical data

## DRRD-...-PS1 – Intermediate position

Control variants

Circuit diagram

1 With 1x 5/3-way valve and 1x 3/2-way valve

Control sequence

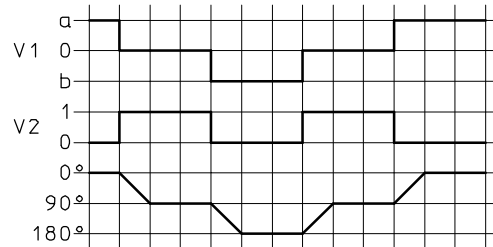
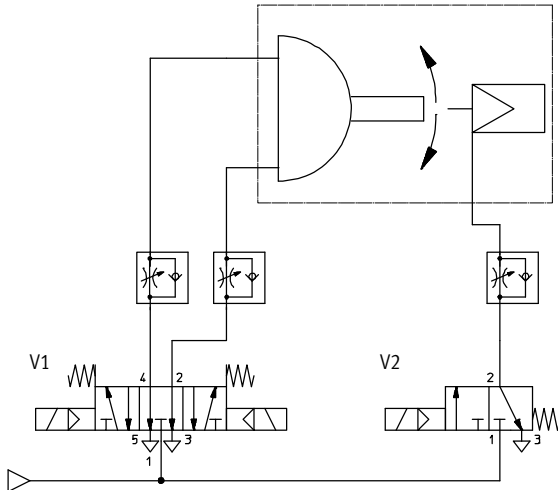

2 With 3x 3/2-way valves

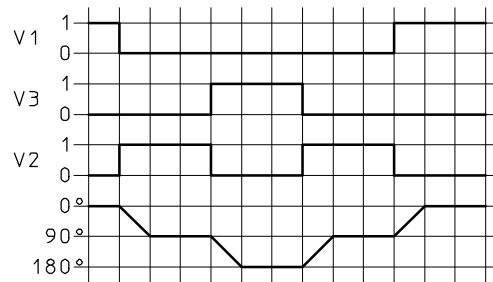
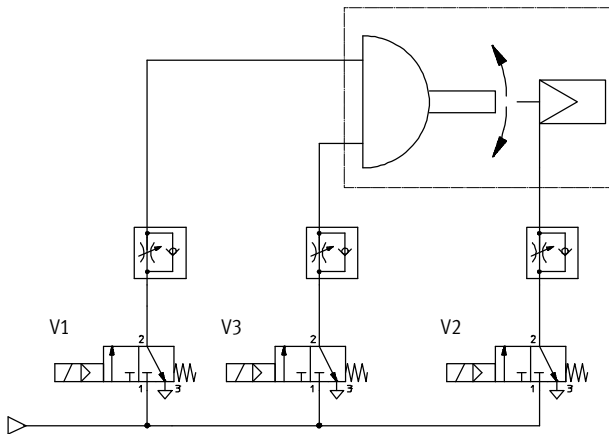

3 With 1x 5/3-way valve and 3x 3/2-way valves

The exhaust air flow control valves for the basic drive can be adjusted separately here.

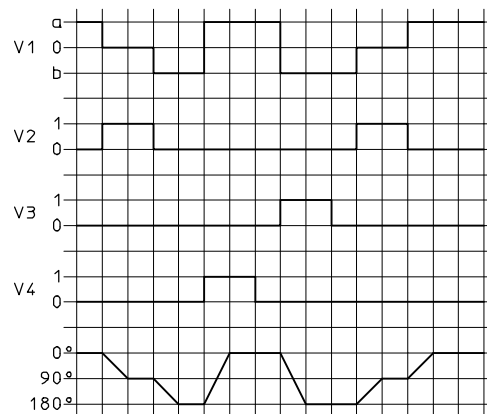
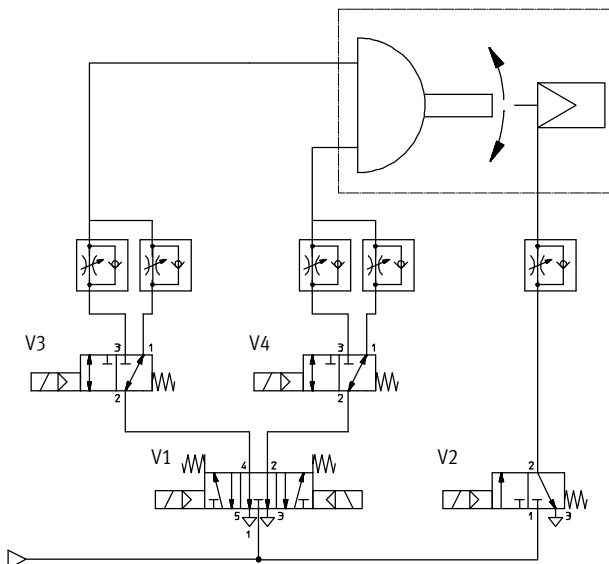

# Twin-piston semi-rotary drives DRRD-16 ... 63

Technical data

## DRRD-...-PS1 – Intermediate position

Max. permissible mass moment of inertia  $J$  at the flanged shaft as a function of swivel time  $t$   
(at room temperature and an operating pressure of 6 bar)

Size 16

End position to intermediate position

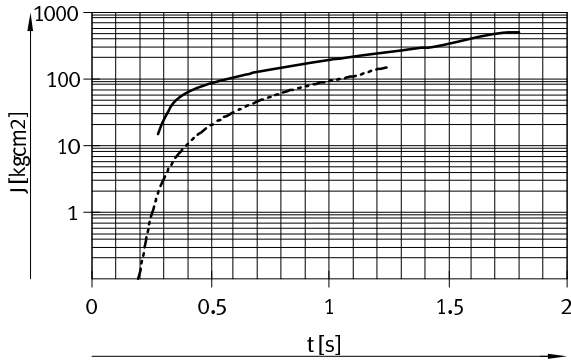

Ranges  
 — DRRD-16-Y9-PS1 → 15 ... 500 kgcm<sup>2</sup>  
 - - - DRRD-16-P-PS1 → 0 ... 150 kgcm<sup>2</sup>

Intermediate position to end position

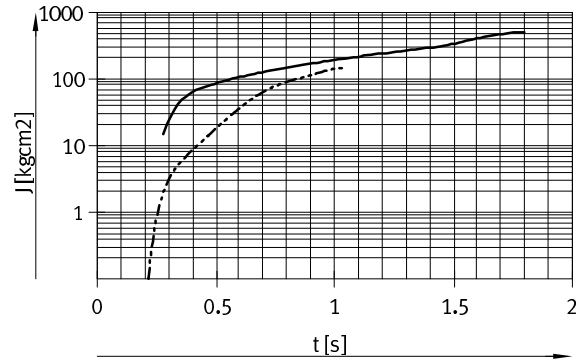

Ranges  
 — DRRD-16-Y9-PS1 → 15 ... 500 kgcm<sup>2</sup>  
 - - - DRRD-16-P-PS1 → 0 ... 150 kgcm<sup>2</sup>

Size 20

End position to intermediate position

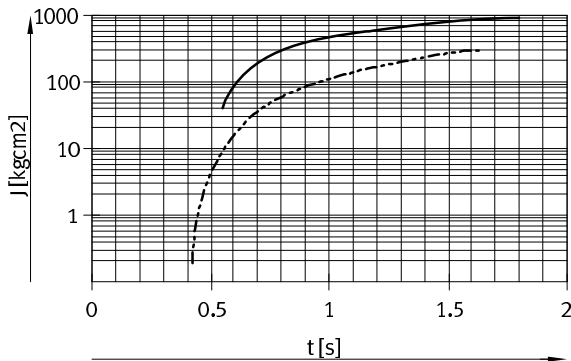

Ranges  
 — DRRD-20-Y9-PS1 → 40 ... 900 kgcm<sup>2</sup>  
 - - - DRRD-20-P-PS1 → 0 ... 300 kgcm<sup>2</sup>

Intermediate position to end position

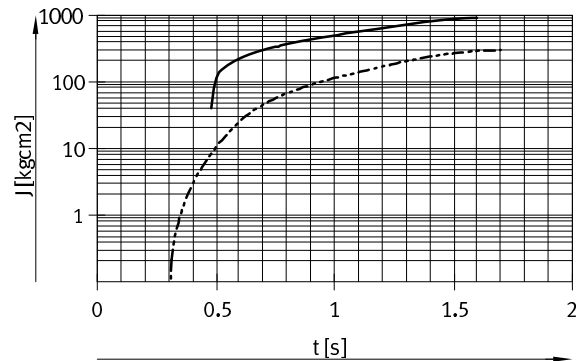

Ranges  
 — DRRD-20-Y9-PS1 → 40 ... 900 kgcm<sup>2</sup>  
 - - - DRRD-20-P-PS1 → 0 ... 300 kgcm<sup>2</sup>

Size 25

End position to intermediate position

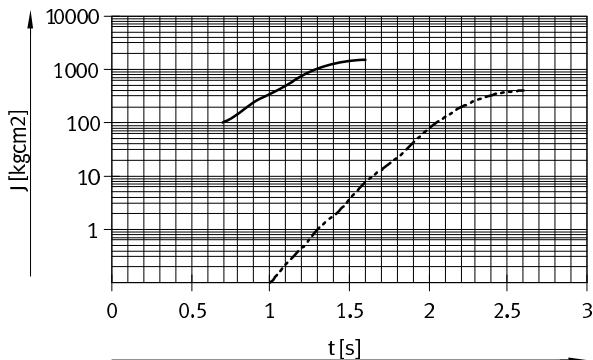

Ranges  
 — DRRD-25-Y9-PS1 → 100 ... 1500 kgcm<sup>2</sup>  
 - - - DRRD-25-P-PS1 → 0 ... 400 kgcm<sup>2</sup>

Intermediate position to end position

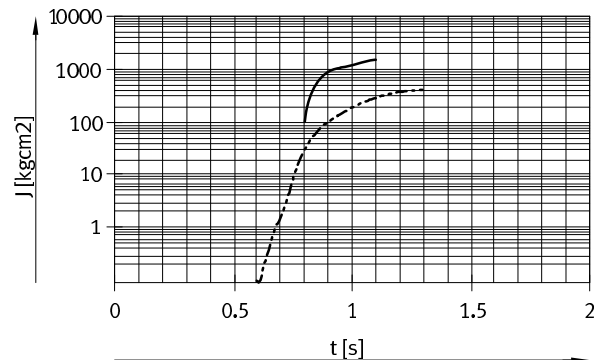

Ranges  
 — DRRD-25-Y9-PS1 → 100 ... 1500 kgcm<sup>2</sup>  
 - - - DRRD-25-P-PS1 → 0 ... 400 kgcm<sup>2</sup>

# Twin-piston semi-rotary drives DRRD-16 ... 63

Technical data

## DRRD-...-PS1 – Intermediate position

Max. permissible mass moment of inertia  $J$  at the flanged shaft as a function of swivel time  $t$   
(at room temperature and an operating pressure of 6 bar)

Size 32

End position to intermediate position

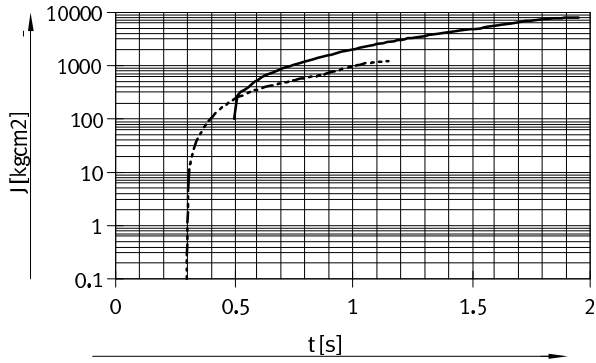

— DRRD-32-Y9-PS1 → 100 ... 8000 kgcm<sup>2</sup>  
 - - - DRRD-32-P-PS1 → 0 ... 500 kgcm<sup>2</sup>

Intermediate position to end position

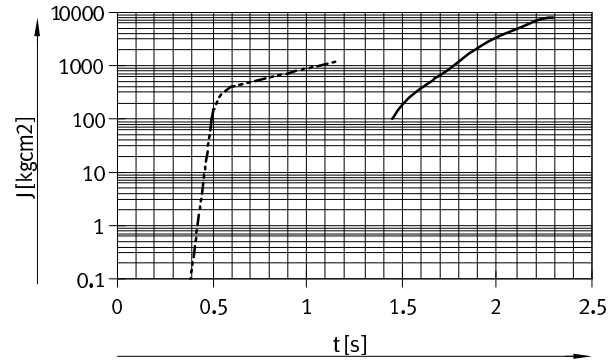

— DRRD-32-Y9-PS1 → 100 ... 8000 kgcm<sup>2</sup>  
 - - - DRRD-32-P-PS1 → 0 ... 500 kgcm<sup>2</sup>

Size 35

End position to intermediate position

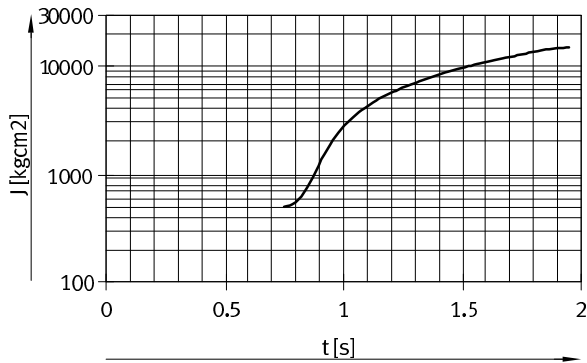

— DRRD-35-Y9-PS1 → 500 ... 15000 kgcm<sup>2</sup>

Intermediate position to end position

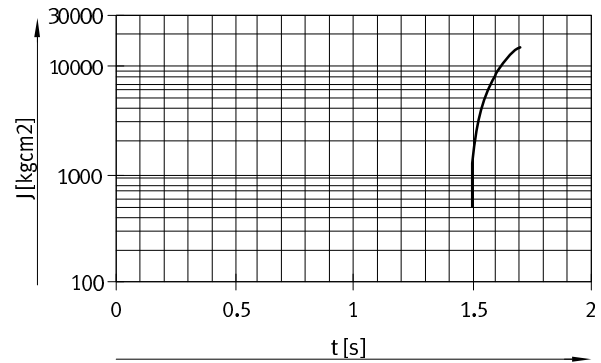

— DRRD-35-Y9-PS1 → 500 ... 15000 kgcm<sup>2</sup>

# Twin-piston semi-rotary drives DRRD-16 ... 63

Technical data

## DRRD-...-PS1 – Intermediate position

Max. permissible mass moment of inertia J at the flanged shaft as a function of swivel time t (at room temperature and an operating pressure of 6 bar)

Size 40

End position to intermediate position

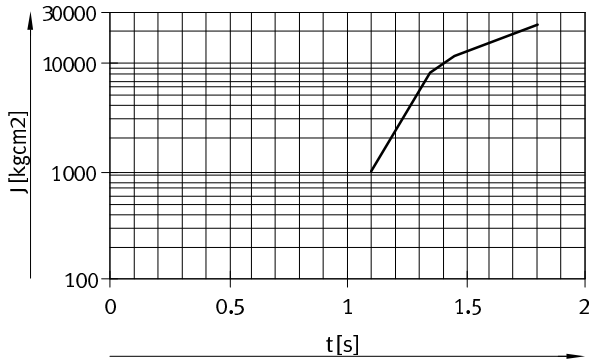

DRRD-40-Y9-PS1

Ranges  
→ 1000 ... 23000 kgcm<sup>2</sup>

Intermediate position to end position

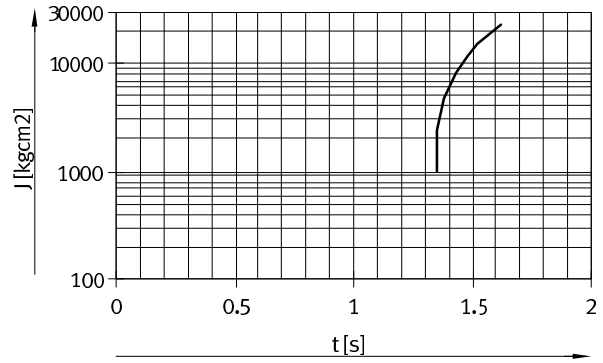

DRRD-40-Y9-PS1

Ranges  
→ 1000 ... 23000 kgcm<sup>2</sup>

Size 50

End position to intermediate position

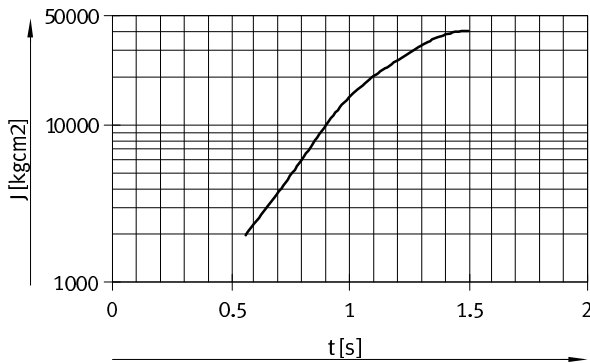

DRRD-50-Y9-PS1

Ranges  
→ 2000 ... 40000 kgcm<sup>2</sup>

Intermediate position to end position

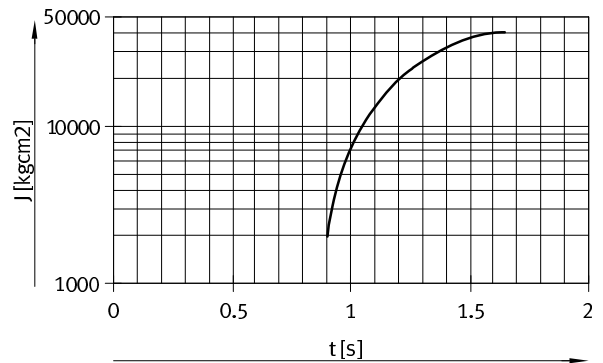

DRRD-50-Y9-PS1

Ranges  
→ 2000 ... 40000 kgcm<sup>2</sup>

# Twin-piston semi-rotary drives DRRD-16 ... 63

Technical data

FESTO

## Dimensions

Download CAD data → [www.festo.com](http://www.festo.com)

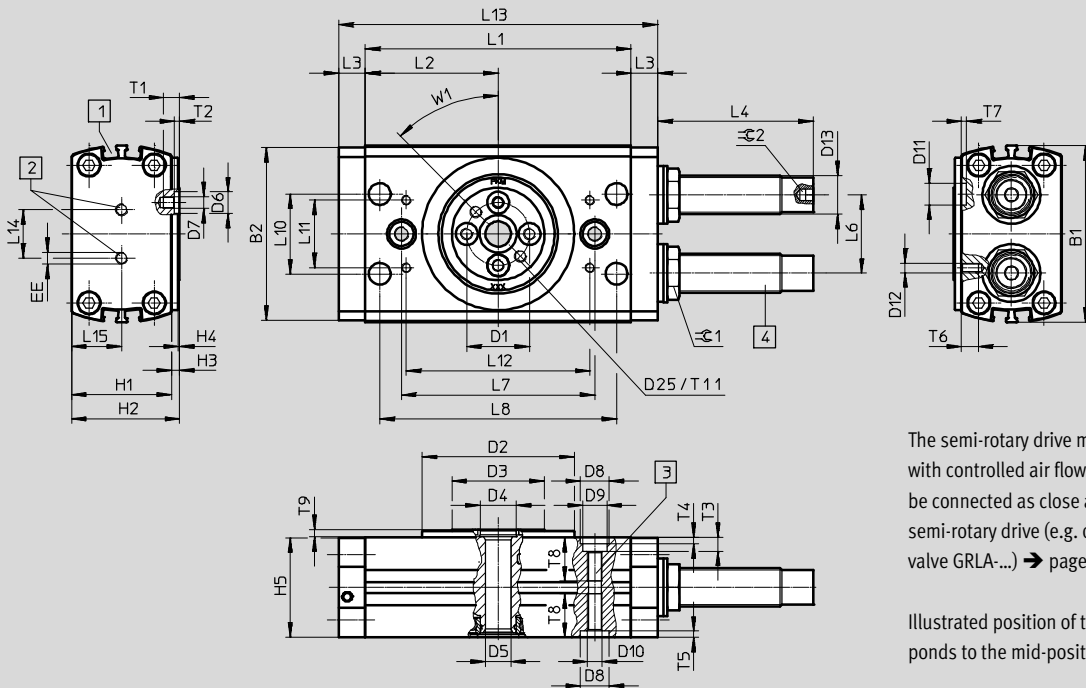

The semi-rotary drive must only be operated with controlled air flow. The throttles should be connected as close as possible to the semi-rotary drive (e.g. one-way flow control valve GRLA-...) → page 64.

Illustrated position of the flanged shaft corresponds to the mid-position (swivel angle 90°).

DRRD-32 ... 40

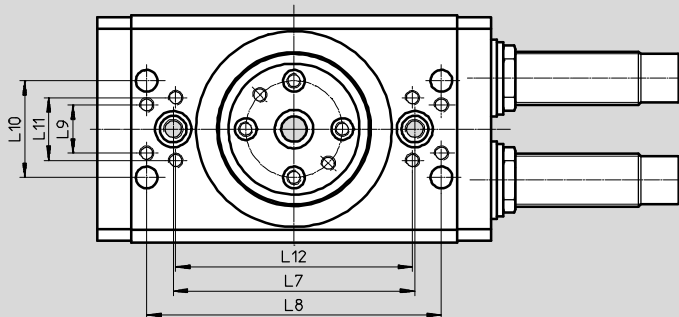

DRRD-...-P

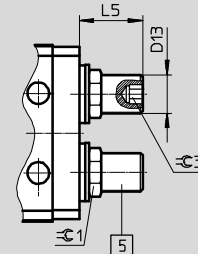

DRRD-50/63

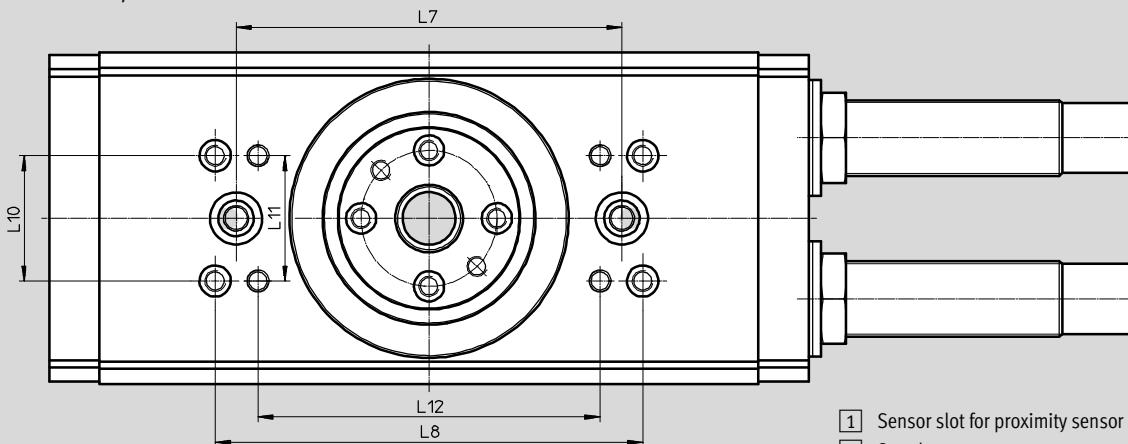

- 1 Sensor slot for proximity sensor
- 2 Supply ports
- 3 Mounting thread
- 4 Shock absorber (DRRD-...-Y9/-Y10/-Y14)
- 5 Cushioning component (DRRD-...-P)

# Twin-piston semi-rotary drive DRRD-16 ... 63

Technical data

Size	B1 ±0.25	B2	D1 ∅ ±0.025	D2 ∅ +0/-0.05	D3 ∅	D4 ∅ H7	D5 ∅ +0.15/-0.05	D6 ∅ H7	D7	D8 ∅ H7	D9 ∅	D10
16	58	56.2	21	50	32	12	8	7	M4	9	8	M5
20	65	63.4	24	56	34.9	12	8	7	M4	9	8	M5
25	73.2	71.5	26	63	38.25	15	10.5	9	M5	12	10	M6
32	94	92.6	40	81	54.2	15	10.5	9	M6	15	11	M8
35	106	104	45	91	59.9	25	10.5	9	M6	15	11	M8
40	113	111	45	91	59.9	25	21	9	M6	15	14	M10
50	132	129.9	54	110	73	25	21	12	M8	15	14	M10
63	159	157	63	135	82.8	25	21	15	M10	25	17	M12

Size	D11 ∅ H7	D12	D13	D25	H1 ±0.1	H2 +0.2/-0.1	H3 +0.3/-0.2	H4 ±0.1	H5	L1 ±0.1	L2	L3 ±0.1
16	7	M3	M10x1	M4	33	35.6	2.6	0.5	32.6	84	42	10.5
20	9	M4	M12x1	M5	36	39.6	3.6	0.5	35.6	86	43	11
25	9	M4	M16x1	M5	41.4	44.7	3.3	0.5	41	110	55	11
32	9	M6	M22x1.5	M6	50	55.5	5.5	1	49.6	135	67.5	14
35	9	M6	M26x1.5	M6	63	67	4	1	62.2	148	74	15
40	9	M6	M26x1.5	M6	68	72	4	1	67.2	199	99.5	15
50	15	M8	M30x1.5	M8	78	83	5	1	77.2	262	131	20
63	15	M10	M37x1.5	M10	100	107	7	2	99.2	335	167.5	25

Size	L6	L7 ±0.02	L8 ±0.2	L9 ±0.15	L10 ±0.02	L11 ±0.15	L12 ±0.2	L13	L14	L15	T1	T2 +0.1
16	23.2	64	74	-	26	22	61	105	20	16.3	5.6	1.6
20	26	70	74	-	33	14	80	108	20	17.8	6	1.6
25	32.25	80	98	-	33	14	98	132	20	20.5	6.6	2.1
32	42.2	100	122	20	40	26	98	163	30	24.8	8	2.1
35	49.6	120	130	44	26	44	105	178	42	31.1	8	2.1
40	56	120	130	44	26	44	105	229	42	33.6	8	2.1
50	64	160	160	34	34	54	132	302	50	39	10.6	2.6
63	78	170	190	60	60	60	149	385	50	49.6	14	3.1

Size	T3	T4 +0.1	T5 +0.1	T6	T7 +0.1	T8	T9 +0.1	T11	EE	W1	≈C 1	≈C 2	≈C 3
16	4.7	2.1	2.1	6.3	1.6	15	2.6	5.6	M5	45°	13	3	5
20	4.7	2.1	2.1	6.3	2.1	15	2.6	5.6	M5	45°	15	4	6
25	5.7	2.6	2.6	7	2.1	18	3.1	5.5	M5	45°	19	5	8
32	6.5	3.1	3.1	7.8	2.1	23.1	3.1	8	G1/8	45°	27	5	10
35	6.5	3.1	3.1	8.5	2.1	22.6	3.5	8	G1/8	45°	32	6	10
40	8.6	3.1	3.1	9	2.1	32	3.5	8	G1/8	45°	32	6	10
50	8.6	3.1	3.1	10.5	3.1	30	3.5	10	G1/4	45°	36	8	-
63	11	3.5	3.5	14	3.1	40	3.5	14	G3/8	45°	46	8	-

Size	Dimension with 180° swivel angle		Swivel angle adjustment range		
	L4	L5	L4 min./max.	L5 min./max.	1 mm = ...°
16	37	17.6	-20/+1.5	-12/+1.4	8.7
20	41.8	18	-21.1/+1.5	-11/+1.4	9
25	63	24.3	-28.9/+1.9	-15/+1.8	6.6
32	78.3	29.5	-34.7/+2.4	-19/+2.3	5.6
35	97.5	40.9	-34.7/+2.4	-27/+2.3	5.6
40	98.2	41.6	-53/+3.2	-28/+3.1	3.6
50	126	-	-74.5/+4.4	-	2.6
63	120	-	-71.7/+7.1	-	1.9

# Twin-piston semi-rotary drives DRRD-16 ... 63

Technical data

Dimensions – Variants

Download CAD data → [www.festo.com](http://www.festo.com)

P... – Pneumatic energy throughfeed

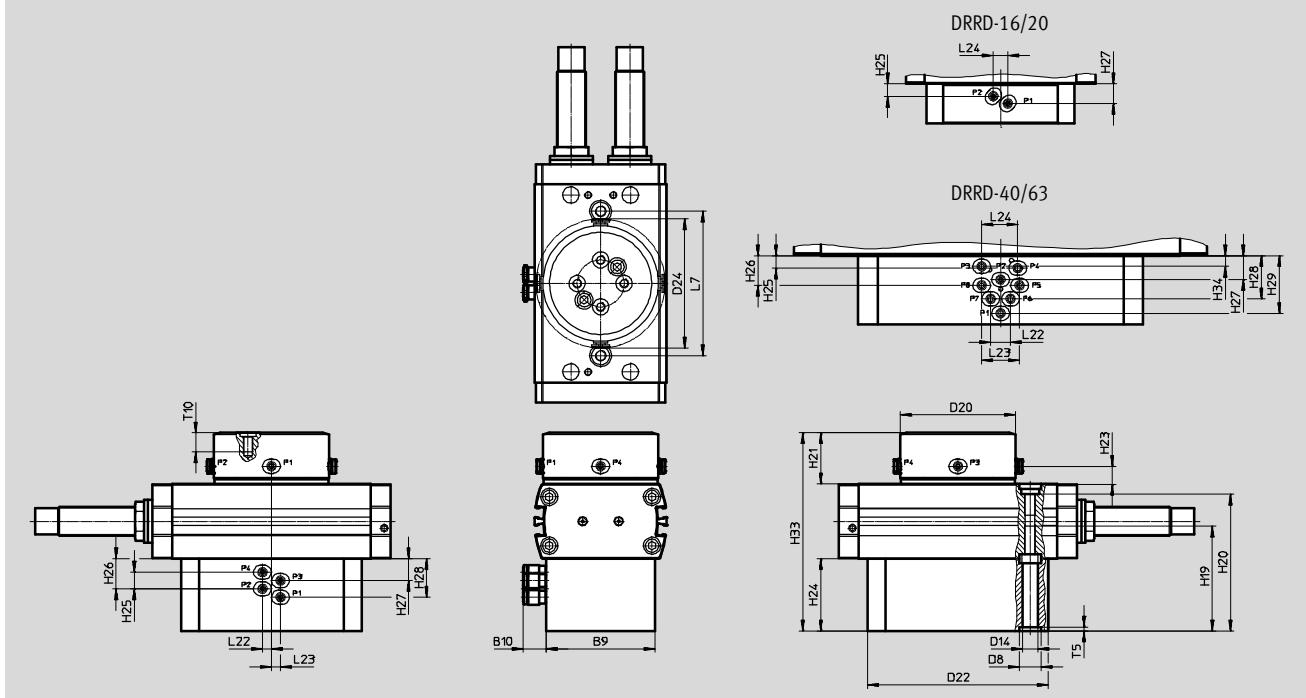

Size	B9	B10	D8 Ø H7	D14 Ø	D20 Ø	D22 Ø
16	52	13.4	9	6	54	82
20	58	13.4	9	6	54	82
25	60	12.8	12	6.5	64	100
32	70	12.8	15	8.5	64	120
35	80	12.8	15	8.5	64	138
40	80	13.4	15	11	89	158
50	80	13.4	15	11	89	190
63	80	13.4	25	13	89	210

Size	D24 Ø	H19	H20	H21	H23	H24
16	70	43	56.4	16.6	7.6	22
20	70	43	59.3	17.6	8.6	22
25	71.6	57	74.7	28.3	9.8	40
32	71.6	62	82.4	31.5	12	40
35	71.6	61.6	95.5	30	10.5	40
40	96.9	70	97.4	21	10.5	38
50	96.9	68	107.4	24	11.5	38
63	96.9	78	127	29	13.5	38



## Twin-piston semi-rotary drives DRRD-16 ... 63

FESTO

Technical data

Size	H25	H26	H27	H28	H29	H33	H34
16	6.9	–	10.9	–	–	71.6	–
20	6.9	–	10.9	–	–	75.6	–
25	7.5	16.7	12.2	21.4	–	109.7	–
32	7.5	16.7	12.2	21.4	–	121.5	–
35	7.5	16.7	12.2	21.4	–	133	–
40	7	16.5	13.3	24	32	127	6
50	7	16.5	13.3	24	32	140	6
63	7	16.5	13.3	24	32	167	6

Size	L7 ±0.02	L22	L23	L24	T5 +0.1	T10
16	64	4	4	8	2.1	8.6
20	70	4	4	8	2.1	8.6
25	80	5	5	–	2.1	9.6
32	100	5	5	–	3.1	11.1
35	120	5	5	–	3.1	11.1
40	120	11	21	20	3.1	10.1
50	160	11	21	20	3.1	14.6
63	170	11	21	20	3.5	17.1

# Twin-piston semi-rotary drives DRRD-16 ... 63

Technical data

## Dimensions – Variants

Download CAD data → [www.festo.com](http://www.festo.com)

P...E... – Pneumatic/electrical energy throughfeed

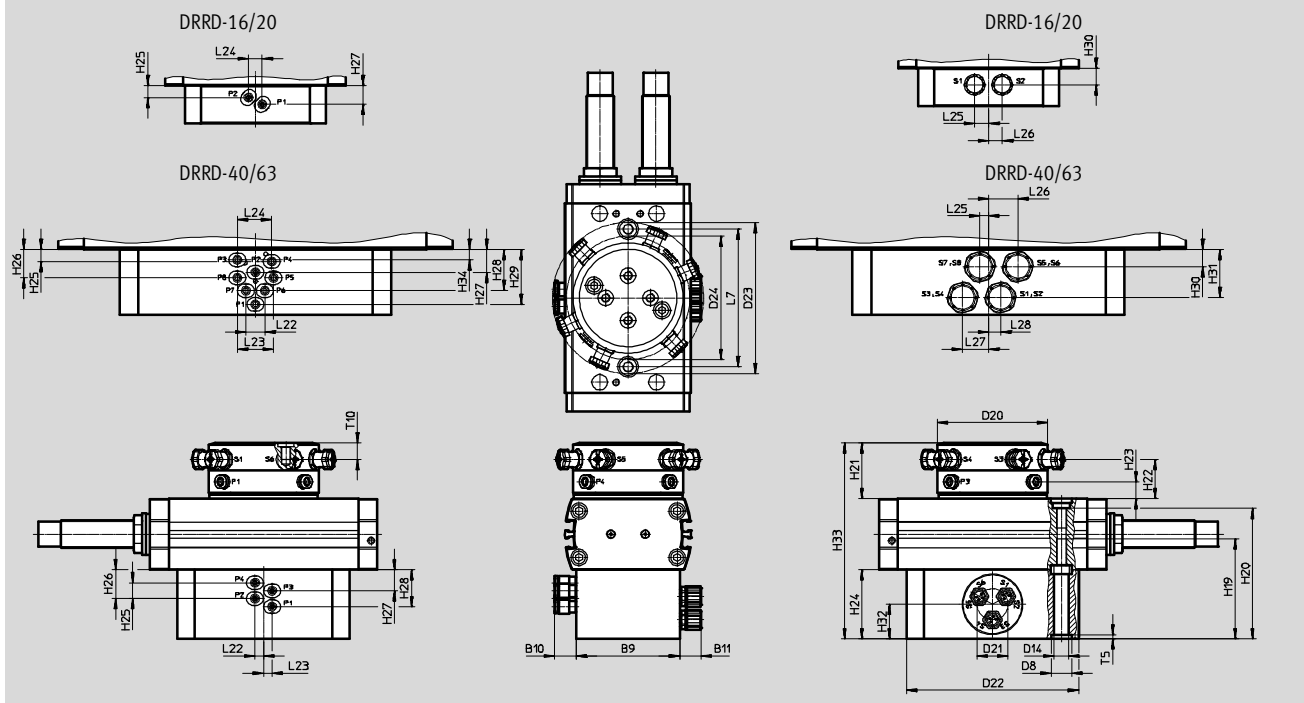

Size	B9	B10	B11	D8 Ø H7	D14 Ø	D20 Ø	D21 Ø	D22 Ø
16	52	13.4	8.5	9	6	54	16	82
20	58	13.4	8.5	9	6	54	16	82
25	60	12.8	12.4	12	6.5	64	18	100
32	70	12.8	12.4	15	8.5	64	18	120
35	80	12.8	12.4	15	8.5	64	18	138
40	80	13.4	24	15	11	89	–	158
50	80	13.4	24	15	11	89	–	190
63	80	13.4	24	25	13	89	–	210

Size	D23 Ø	D24 Ø	H21	H22	H23	H24	H25	H26
16	71.1	70	28.6	21.1	7.6	28	6.9	–
20	71.1	70	29.6	22.1	8.6	28	6.9	–
25	89.8	71.6	32.3	22.8	9.8	40	7.5	16.7
32	89.8	71.6	34.5	25	12	40	7.5	16.7
35	89.8	71.6	33	23.5	10.5	40	7.5	16.7
40	138.5	96.9	40	28.5	10.5	38	7	16.5
50	138.5	96.9	44	32.5	11.5	38	7	16.5
63	138.5	96.9	48	36.5	13.5	38	7	16.5

# Twin-piston semi-rotary drives DRRD-16 ... 63

Technical data

Size	H27	H28	H29	H30	H31	H32	H33	H34	L7 ±0.02
16	10.9	–	–	15.5	–	–	89.6	–	64
20	10.9	–	–	15.5	–	–	93.6	–	70
25	12.2	21.4	–	–	–	20	113.7	–	80
32	12.2	21.4	–	–	–	20	124.5	–	100
35	12.2	21.4	–	–	–	20	136	–	120
40	13.3	24	32	17	22	–	146	6	120
50	13.3	24	32	17	22	–	160	6	160
63	13.3	24	32	17	22	–	186	6	170

Size	L22	L23	L24	L25	L26	L27	L28	T5 +0.1	T10
16	4	4	8	7	7	–	–	2.1	8.6
20	4	4	8	7	7	–	–	2.1	8.6
25	5	5	–	–	–	–	–	2.1	9.6
32	5	5	–	–	–	–	–	3.1	11.1
35	5	5	–	–	–	–	–	3.1	11.1
40	11	21	20	10	10	30	30	3.1	10.1
50	11	21	20	10	10	30	30	3.1	14.6
63	11	21	20	10	10	30	30	3.5	17.1

# Twin-piston semi-rotary drives DRRD-16 ... 63

Technical data

Dimensions – Variants

Download CAD data → [www.festo.com](http://www.festo.com)

Y12 – With external shock absorber

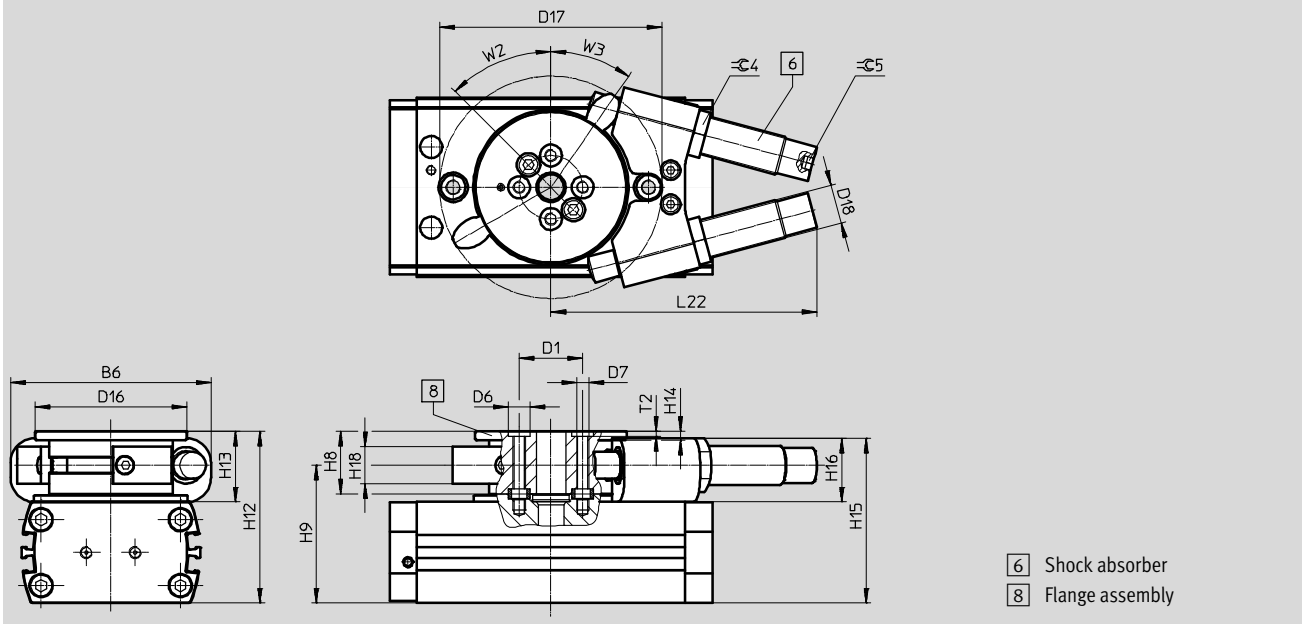

Size	B6 ±0.2	D1 ∅ ±0.025	D6 ∅ H7	D7	D16 ∅	D17	D18	H8 ±0.1	H9	H12
16	58	21	7	M4	49	69.4	M10x1	17	43.1	52.6
20	75	24	7	M4	62	91	M12x1	25.6	51.2	65.2
25	82	26	9	M5	62	91	M16x1	25.6	56.5	70.3
32	120	40	9	M6	79	126.2	M22x1.5	31.5	68.5	87
35	133	45	9	M6	89	146.7	M22x1.5	34	83	101
40	133	45	9	M6	89	146.7	M22x1.5	34	88	106
50	152	54	12	M8	110	165.2	M26x1.5	42	101.5	125
63	186	63	15	M10	130	212.2	M30x1.5	52	129.5	159

Size	H13	H14	H15	H16	H18	L22 Max.	T2 +0.1	W2	W3	∠ 4	∠ 5
16	19.6	3.5	51	18	10	65.2	1.6	45°	36°	13	3
20	29.2	3.5	59.5	23.5	15	85.3	1.6	45°	38°	15	4
25	28.9	3.5	67.4	26	15	108.9	2.1	45°	35°	19	5
32	37	4	85	35	22	149.7	2.1	45°	35°	27	5
35	38	5	99	36	21	155.5	2.1	45°	38°	27	5
40	38	5	104	36	21	155.5	2.1	45°	38°	27	5
50	47	6	123	45	30	171.6	2.6	45°	33°	32	6
63	59	6	155.5	55.5	36	228	3.1	45°	36°	36	8

# Twin-piston semi-rotary drives DRRD-16 ... 63

Technical data

FESTO

## Dimensions – Variants

Download CAD data → [www.festo.com](http://www.festo.com)

PS1 – Intermediate position

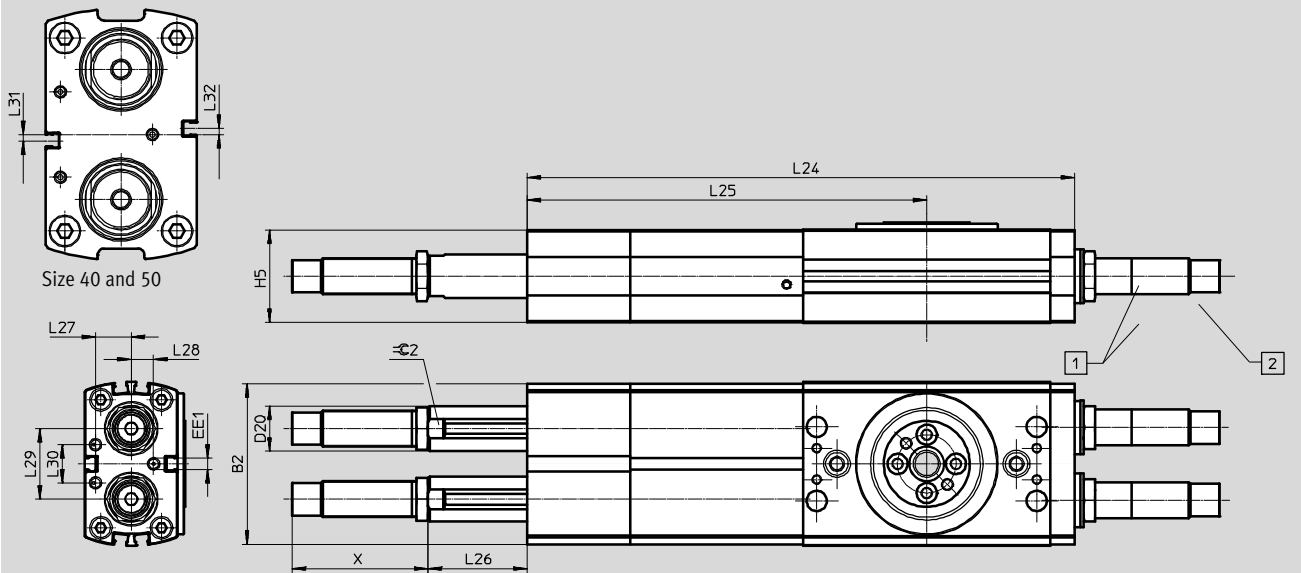

Dimensions for X → page 41

- 1 Supply ports to rotate basic drive
- 2 Supply port to rotate into intermediate position

Size	B2	H5	L24	L25	L26		L27
					Min.	Max.	
16	56.2	32.6	193.1	140.6	0.3	21.5	12
20	63.4	35.6	205.1	151.1	4.5	28.4	14
25	71.5	41	244.1	178.1	14.1	44.2	15.9
32	92.6	49.6	320.1	238.6	3.4	43.5	19.5
35	104	62.2	343.1	254.1	14.8	54.5	25
40	111	67.2	392.1	277.6	9	54.1	27
50	129.9	77.2	542.6	391.6	12.3	86	30



Size	L28	L29	L30	L31	L32	D20 ∅	EE1	∅ 2
16	6.2	21.65	15	–	–	14	M5	12
20	9	26.25	16	–	–	16	M5	14
25	10	31.45	17	–	–	20	M5	18
32	14	38.45	16	–	–	28	M5	24
35	18	49.6	18	–	–	32	M5	27
40	14	58	38	2.6	2.6	32	M5	27
50	20	78	44	5	5	36	G $\frac{1}{8}$	32

# Twin-piston semi-rotary drives DRRD-16 ... 63

FESTO

Technical data

## ★ Core product range

Ordering data – Stock items				
DRRD	Size	Swivel angle [°]	Part No.	Type
P – Elastic cushioning rings/pads at both ends				
	16	180	★ 1577238	DRRD-16-180-FH-PA
	20		★ 1395606	DRRD-20-180-FH-PA
	25		★ 1359980	DRRD-25-180-FH-PA
	32		★ 1578512	DRRD-32-180-FH-PA
	35		★ 1526825	DRRD-35-180-FH-PA
	40		★ 1503269	DRRD-40-180-FH-PA
Y9 – Linear shock absorber, self-adjusting at both ends				
	16	180	★ 1644389	DRRD-16-180-FH-Y9A
	20		★ 1427379	DRRD-20-180-FH-Y9A
	25		★ 1360248	DRRD-25-180-FH-Y9A
	32		★ 1578518	DRRD-32-180-FH-Y9A
	35		★ 1547102	DRRD-35-180-FH-Y9A
	40		★ 1526986	DRRD-40-180-FH-Y9A

Festo core product range

★ Generally ready for shipping ex works in 24 hours

☆ Generally ready for shipping ex works in 5 days

# Twin-piston semi-rotary drives DRRD-16 ... 63

Ordering data – Modular product system

Ordering table												
Size	16	20	25	32	35	40	50	63	Condi- tions	Code	Entry code	
<b>M</b> Part no.	<b>574399</b>	<b>574400</b>	<b>574401</b>	<b>574402</b>	<b>574403</b>	<b>574404</b>	<b>574405</b>	<b>574407</b>				
Function	Semi-rotary drive									<b>DRRD</b>	DRRD	
Size	16	20	25	32	35	40	50	63		-...		
Nominal swivel angle	180°									<b>-180</b>	-180	
Output shaft	Flanged shaft, hollow									<b>-FH</b>	-FH	
<b>O</b> Energy throughfeed	None									-		
	Pneumatic, 2 ducts		-							<b>P2</b>		
	Pneumatic, 2 ducts; electric, 2 signals		-							<b>P2E2</b>		
	-		Pneumatic, 4 ducts			-				<b>P4</b>		
	-		Pneumatic, 4 channels; electric, 6 signals			-				<b>P4E6</b>		
	-		-			Pneumatic, 8 ducts				<b>P8</b>		
	-		-			Pneumatic, 8 ducts; electric, 8 signals				<b>P8E8</b>		
<b>M</b> Cushioning	Elastic cushioning rings/pads at both ends							-		<b>-P</b>		
	Linear shock absorber, self-adjusting at both ends									<b>-Y9</b>		
	-		Linear shock absorber, self- adjusting at both ends, hard		-			Linear shock absorber, self-adjusting at both ends, hard			<b>-Y10</b>	
	Linear shock absorber, self-adjusting at both ends, external								<b>1</b> <b>5</b>	<b>-Y12</b>		
	Linear shock absorber, self-adjusting at both ends, soft							-		<b>-Y14</b>		
Position sensing	Via proximity sensor									<b>A</b>	A	
<b>O</b> EU certification	None											
	II 2GD									<b>2</b>	<b>-EX4</b>	
Intermediate position	Without							-				
	1 intermediate position							-	<b>3</b>	<b>-PS1</b>		
End-position locking	Without											
	At both ends									<b>4</b> <b>5</b>	<b>-E1</b>	
Sensor mounting, external	Without											
	Mounting rail for proximity sensor									<b>5</b>	<b>-R</b>	
Version	Standard											
	Splash-proof design										<b>-SG</b>	
Operating instructions	With operating instructions											
	Without operating instructions										<b>-DN</b>	

- 1 Y12** Not with end-position locking E1 and splash-proof design SG
- 2 EX4** Not with end-position locking E1, energy throughfeed P2E2, P4E6, P8E8 and intermediate position PS1
- 3 PS1** Not with cushioning Y10, Y14 and with cushioning P only for size 16 ... 32
- 4 E1** Not with sensor mounting R and splash-proof design SG
- 5 Y12, E1, R** Not with energy throughfeed P2, P2E2, P4, P4E6, P8, P8E8

**Transfer order code**

**DRRD** -  - **180** - **FH** -  -  **A** -  -  -  -  -

# Twin-piston semi-rotary drives DRRD

Accessories

FESTO

## Drive shaft DARF-Q11

For size 12 ... 40

Materials:

Tempered steel

RoHS compliant

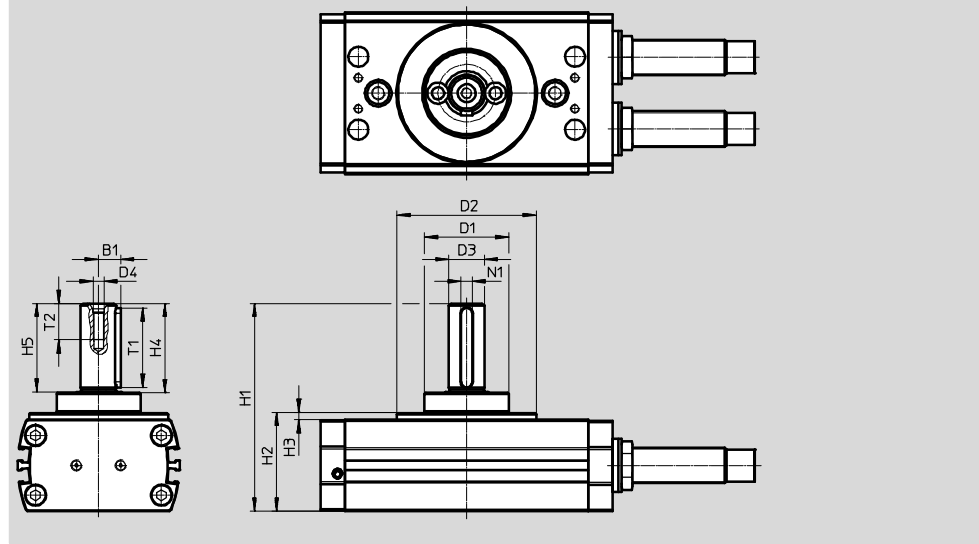

Dimensions and ordering data								
For size	B1	D1	D2	D3	D4	H1	H2	H3
	+0.1/-0.2	∅ -0.2	∅	∅ g7				
12	4.8	30	30	8	M3	56.75±0.3	30.75±0.2	0.75+0.2/-0.6
16	6.2	32	50 <sub>h7</sub>	10	M3	66.1+0.3/-0.2	35.6+0.2/-0.1	2.6+0.3/-0.2
20	7.5	35	56 <sub>h7</sub>	12	M4	76.8+0.3/-0.2	39.6+0.2/-0.1	3.6+0.3/-0.2
25	10	38	63 <sub>h7</sub>	16	M5	94+0.3/-0.2	44.7+0.2/-0.1	3.3+0.3/-0.2
32	12.5	55	81 <sub>h7</sub>	20	M6	114.8+0.3/-0.2	55.5+0.2/-0.1	5.5+0.3/-0.2
35	13.5	60	91 <sub>h7</sub>	22	M8	126.2+0.3/-0.2	67+0.2/-0.1	4+0.3/-0.2
40	13.5	60	91 <sub>h7</sub>	22	M8	131.2+0.3/-0.2	72+0.2/-0.1	4+0.3/-0.2

For size	H4	H5	T1	T2	N1 <sup>2)</sup>	Weight	Part No.	Type <sup>1)</sup>
				+2	P9	[g]		
12	20.5	20±0.1	16 <sup>+0.2</sup>	11.6	2	38	<b>4835942</b>	<b>DARF-Q11-12</b>
16	23.5	23±0.1	18.1 <sup>+0.3</sup>	11.6	3	60	<b>4835943</b>	<b>DARF-Q11-16</b>
20	30.5	30±0.1	25.1 <sup>+0.3</sup>	13.5	4	79	<b>4835941</b>	<b>DARF-Q11-20</b>
25	40.5	40±0.2	36.1 <sup>+0.3</sup>	16.5	5	145	<b>4835938</b>	<b>DARF-Q11-25</b>
32	50.5	50±0.2	45.1 <sup>+0.3</sup>	21	6	287	<b>4835940</b>	<b>DARF-Q11-32</b>
35	50.5	50±0.2	45.1 <sup>+0.3</sup>	32	6	350	<b>4835939</b>	<b>DARF-Q11-35/40</b>
40	50.5	50±0.2	45.1 <sup>+0.3</sup>	32	6	350	<b>4835939</b>	<b>DARF-Q11-35/40</b>

1) Suitable for ATEX

2) Feather key according to DIN 6885



# Twin piston semi-rotary drives DRRD

Accessories

## Clamping unit DADL-EL

For size 16 ... 63

(order code: E1)

Stock items

Materials:

Housing: Anodised aluminium

Bearing: Plastic

RoHS compliant

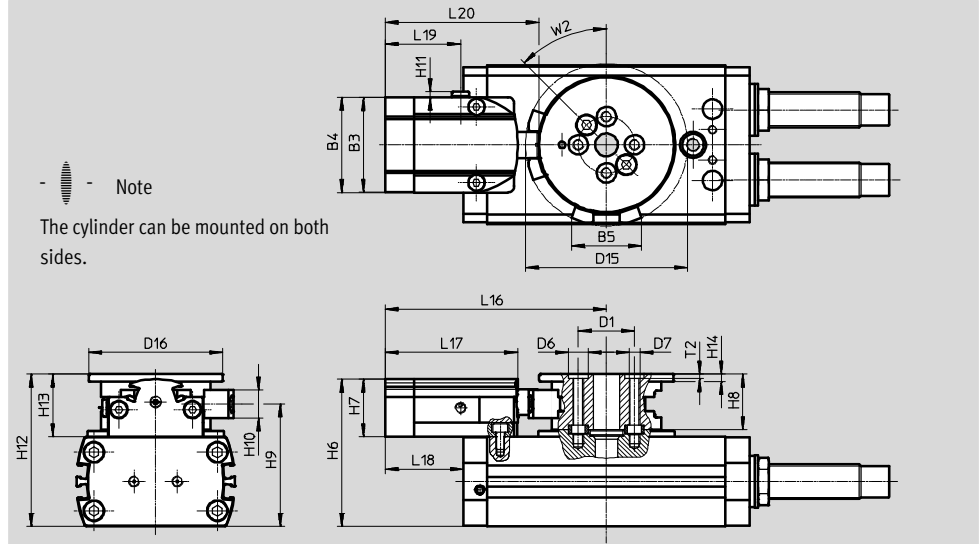

Dimensions and ordering data												
For size	B3	B4	B5	D1	D6	D7	D15	D16	H6	H7	H8	H9
	±0.2	±0.2		∅ ±0.025	∅ H7		∅	∅		±0.15	±0.1	
16	37.6	38	26.9	21	7	M4	61.9	49	51	18	17	43.1
20	43.6	44	32.4	24	7	M4	74.9	62	62.5	26.5	25.6	51.2
25	43.6	44	32.4	26	9	M5	74.9	62	67.9	26.5	25.6	56.5
32	43.6	44	39.4	40	9	M6	95.4	79	79	26.7	31.5	68.5
35	57.6	58	50.2	45	9	M6	110.9	89	98	35	34	83
40	57.6	58	50.2	45	9	M6	110.9	89	103	35	34	88
50	71.4	72	59.6	54	12	M8	124.3	110	123	45	42	101.5
63	71.4	72	65.8	63	15	M10	148.5	130	149	49	52	129.5

For size	H10	H11	H12	H13	H14	L16	L17	L18	L19	L20	T2	W2
											+0.1	
16	9	2.5	52.6	19.6	3.5	83	50	30.5	34	58.3	1.6	45°
20	13	2.5	65.2	29.2	3.5	102.2	61.2	48.2	34.8	71.1	1.6	45°
25	13	2.5	70.3	28.9	3.5	102.2	61.2	36.2	34.8	71.1	2.1	45°
32	17	2.5	87	37	4	112.2	61.2	30.7	34.8	71.1	2.1	45°
35	14.8	2.5	101	38	5	132.5	70.6	43.5	42.6	85.4	2.1	45°
40	14.8	2.5	106	38	5	132.5	70.6	18	42.6	85.4	2.1	45°
50	19	4.6	125	47	6	151	81	0	46	98	2.6	45°
63	22	4.6	159	59	6	163	81	-29.5	46	99.5	3.1	45°

For size	Pneumatic connection	Operating pressure [bar]	Position sensing	Adjustable swivel angle [°]	Weight [g]	Part No.	Type
16	M5	5 ... 8	Via proximity sensor	60 ... 200	166	<b>1692770</b>	<b>DADL-EL-Q11-16</b>
20					382	<b>1579786</b>	<b>DADL-EL-Q11-20</b>
25					370	<b>1568183</b>	<b>DADL-EL-Q11-25</b>
32					600	<b>1631139</b>	<b>DADL-EL-Q11-32</b>
35					900	<b>1544900</b>	<b>DADL-EL-Q11-35/40</b>
40	G <sup>1</sup> / <sub>8</sub>				900	<b>1544900</b>	<b>DADL-EL-Q11-35/40</b>
50					1610	<b>1796637</b>	<b>DADL-EL-Q11-50</b>
63					2380	<b>1941568</b>	<b>DADL-EL-Q11-63</b>

# Twin-piston semi-rotary drives DRRD

Accessories

FESTO

## Sensing kit DASI-...-KT

For size 16 ... 63

(order code: R)

Stock items

Materials:

Anodised aluminium

RoHS compliant

For sensing the piston position using inductive proximity sensors SIES

→ page 61



- 7 Sensor slot for proximity sensor
- 8 Flange assembly: dimensions  
→ page 57

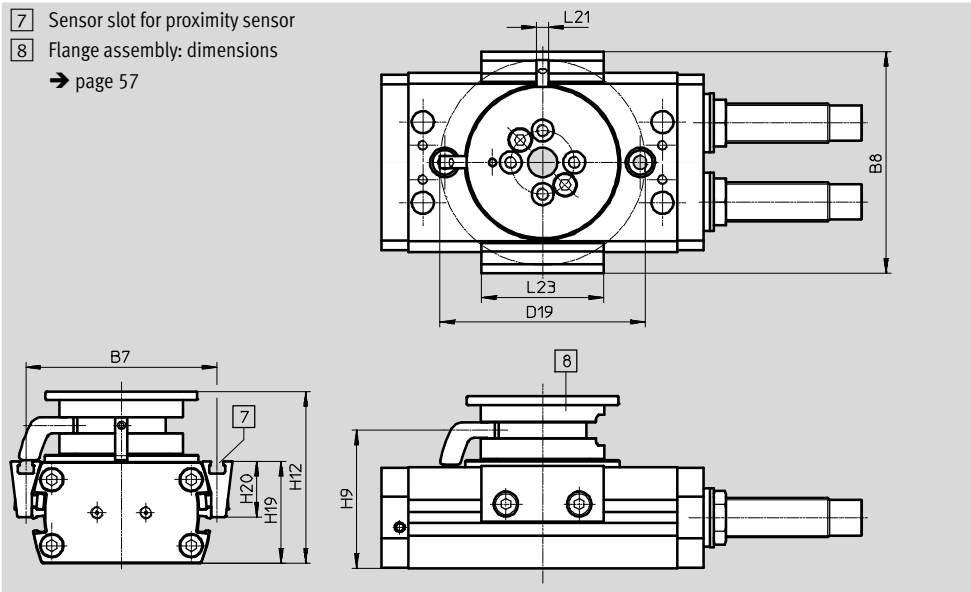

### Dimensions and ordering data

For size	B7	B8	D19 ∅	H9	H12	H19
16	64.4	76.1	70.9	43.1	52.6	33.5
20	74	85.7	84	51.2	65.2	36.4
25	78.2	90.7	84	56.5	70.3	41.8
32	100	113.5	107.5	68.5	87	50.5
35	116	132.9	125.2	83	101	63.5
40	118	135.8	125.2	88	106	68.5
50	136	155.3	146.6	101.5	125	79.1
63	163	185.3	173.9	129.5	159	101





For size	H20 ±0.1	L21	L23	Weight [g]	Part No.	Type <sup>1)</sup>
16	18.5	5	50	110	1693008	DASI-Q11-16-A-KT
20	20.2	5	50	192	1580899	DASI-Q11-20-A-KT
25	22.8	5	50	192	1568461	DASI-Q11-25-A-KT
32	26.5	7	50	366	1632097	DASI-Q11-32-A-KT
35	33.1	7	50	485	1551144	DASI-Q11-35-A-KT
40	35.5	7	50	485	1550027	DASI-Q11-40-A-KT
50	43	7	50	810	1797135	DASI-Q11-50-A-KT
63	55	7	50	1390	1946877	DASI-Q11-63-A-KT

1) Suitable for ATEX

# Twin-piston semi-rotary drives DRRD

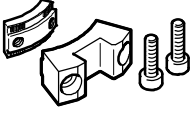
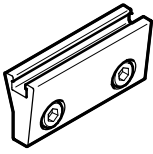
Accessories

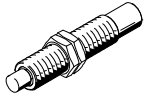
FESTO



Ordering data <sup>2)</sup>						
	For size	Description	Weight [g]	Part No.	Type	PU <sup>1)</sup>
<b>Clamping component DADL-EC</b>						
	16	For securing an intermediate position in combination with the clamping unit DADL-EL	18	<b>1692496</b>	<b>DADL-EC-Q11-16</b>	1
	20, 25		36	<b>1435411</b>	<b>DADL-EC-Q11-20/25</b>	
	32		67	<b>1631170</b>	<b>DADL-EC-Q11-32</b>	
	35, 40		98	<b>1535091</b>	<b>DADL-EC-Q11-35/40</b>	
	50		140	<b>1796626</b>	<b>DADL-EC-Q11-50</b>	
	63		220	<b>1941355</b>	<b>DADL-EC-Q11-63</b>	
	<b>Sensor bracket DASI-...-SR<sup>3)</sup></b>					
	16	Additional sensing option in combination with the sensing kit DASI-...-KT	28	<b>1692983</b>	<b>DASI-Q11-16-A-SR</b>	2
	20		32	<b>1581420</b>	<b>DASI-Q11-20-A-SR</b>	
	25		32	<b>1568451</b>	<b>DASI-Q11-25-A-SR</b>	
	32		42	<b>1631997</b>	<b>DASI-Q11-32-A-SR</b>	
	35		62	<b>1550870</b>	<b>DASI-Q11-35-A-SR</b>	
	40		62	<b>1548054</b>	<b>DASI-Q11-40-A-SR</b>	
	50		75	<b>1797071</b>	<b>DASI-Q11-50-A-SR</b>	
	63		110	<b>1971563</b>	<b>DASI-Q11-63-A-SR</b>	
	<b>Switch lug DASI-...-SL<sup>3)</sup></b>					
	16	Additional sensing option in combination with the sensing kit DASI-...-KT	2.5	<b>1692969</b>	<b>DASI-Q11-16-A-SL</b>	1
	20, 25		4	<b>1568436</b>	<b>DASI-Q11-20/25-A-SL</b>	
	32		6	<b>1631824</b>	<b>DASI-Q11-32-A-SL</b>	
	35, 40		8	<b>1548155</b>	<b>DASI-Q11-35/40-A-SL</b>	
	50		10	<b>1797021</b>	<b>DASI-Q11-50-A-SL</b>	
	63		15	<b>1971550</b>	<b>DASI-Q11-63-A-SL</b>	
	<b>Shock absorber DYSC<sup>3)</sup></b>					
	12	<ul style="list-style-type: none"> <li>Self-adjusting shock absorbers for use as external cushioning (Y12)</li> <li>Included in the scope of delivery for semi-rotary drive DRRD-...-Y12</li> </ul>	9	<b>548011</b>	<b>DYSC-5-5-Y1F</b>	1
	16		17	<b>548012</b>	<b>DYSC-7-5-Y1F</b>	
	20		36	<b>548013</b>	<b>DYSC-8-8-Y1F</b>	
	25		81	<b>548014</b>	<b>DYSC-12-12-Y1F</b>	
	32, 35, 40		210	<b>553593</b>	<b>DYSC-16-18-Y1F</b>	
	50		370	<b>2479149</b>	<b>DYSC-20-18-Y1F</b>	
	63		575	<b>2480234</b>	<b>DYSC-25-25-Y1F</b>	
	<b>Centring sleeve ZBH<sup>3)</sup></b>					
	8, 10	<ul style="list-style-type: none"> <li>For centring the semi-rotary drive</li> <li>2 included in the scope of delivery for the semi-rotary drive</li> </ul>	1	<b>186717</b>	<b>ZBH-7</b>	10
	12, 16, 20		1	<b>150927</b>	<b>ZBH-9</b>	
	25		1	<b>189653</b>	<b>ZBH-12</b>	
	32 ... 50		3	<b>191409</b>	<b>ZBH-15</b>	
	63		5	<b>8023856</b>	<b>ZBH-25</b>	
	8, 10, 12	<ul style="list-style-type: none"> <li>For centring attachments on the flanged shaft</li> <li>Centring sleeves included in the scope of delivery for the attachments</li> </ul>	1	<b>189652</b>	<b>ZBH-5</b>	
	16, 20		1	<b>186717</b>	<b>ZBH-7</b>	
	25 ... 40		1	<b>150927</b>	<b>ZBH-9</b>	
	50		1	<b>189653</b>	<b>ZBH-12</b>	
	63		3	<b>191409</b>	<b>ZBH-15</b>	

- 1) Packaging unit  
 2) Stock items  
 3) Suitable for ATEX

# Twin-piston semi-rotary drives DRRD

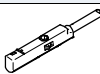

Accessories

FESTO

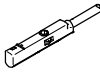
Proximity sensor for size 8 ... 12						
Ordering data – Proximity sensors for C-slot, magneto-resistive						Technical data → Internet: smt
	Type of mounting	Switching output	Electrical connection, outlet direction	Cable length [m]	Part No.	Type
N/O contact						
	Inserted in the slot from above	PNP	Cable, 3-wire, lengthwise	2.5	★ 551373	SMT-10M-PS-24V-E-2,5-L-OE
			Plug M8x1, 3-pin, lengthwise	0.3	★ 551375	SMT-10M-PS-24V-E-0,3-L-M8D
			Plug M8x1, 3-pin, lateral	0.3	551376	SMT-10M-PS-24V-E-0,3-Q-M8D
	Insertable in the slot lengthwise	PNP	Cable, 3-wire, lateral	2.5	547862	SMT-10G-PS-24V-E-2,5Q-OE
			Plug M8x1, 3-pin, lateral	0.3	547863	SMT-10G-PS-24V-E-0,3Q-M8D

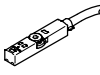
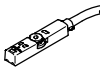
Ordering data – Proximity sensors for C-slot, magnetic reed						
Ordering data – Proximity sensors for C-slot, magnetic reed						Technical data → Internet: sme
	Type of mounting	Switching output	Electrical connection, outlet direction	Cable length [m]	Part No.	Type
N/O contact						
	Inserted in the slot from above	Contacting	Plug M8x1, 3-pin, lengthwise	0.3	★ 551367	SME-10M-DS-24V-E-0,3-L-M8D
			Cable, 3-wire, lengthwise	2.5	★ 551365	SME-10M-DS-24V-E-2,5-L-OE
			Cable, 2-wire, lengthwise	2.5	★ 551369	SME-10M-ZS-24V-E-2,5-L-OE

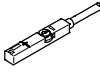
Proximity sensors for size 16 ... 63						
Ordering data – Proximity sensors for T-slot, magneto-resistive						Technical data → Internet: smt
	Type of mounting	Switching output	Electrical connection	Cable length [m]	Part No.	Type
N/O contact						
	Inserted in the slot from above, flush with the cylinder profile, short design	PNP	Cable, 3-wire	2.5	★ 574335	SMT-8M-A-PS-24V-E-2,5-OE
			Plug connector M8x1, 3-pin	0.3	★ 574334	SMT-8M-A-PS-24V-E-0,3-M8D
			Plug connector M12x1, 3-pin	0.3	★ 574337	SMT-8M-A-PS-24V-E-0,3-M12
		NPN	Cable, 3-wire	2.5	★ 574338	SMT-8M-A-NS-24V-E-2,5-OE
			Plug connector M8x1, 3-pin	0.3	★ 574339	SMT-8M-A-NS-24V-E-0,3-M8D
N/C contact						
	Inserted in the slot from above, flush with the cylinder profile, short design	PNP	Cable, 3-wire	7.5	★ 574340	SMT-8M-A-PO-24V-E-7,5-OE

Ordering data – Proximity sensors for T-slot, magnetic reed						
Ordering data – Proximity sensors for T-slot, magnetic reed						Technical data → Internet: sme
	Type of mounting	Switching output	Electrical connection	Cable length [m]	Part No.	Type
N/O contact						
	Inserted in the slot from above, flush with the cylinder profile	Contacting	Cable, 3-wire	2.5	★ 543862	SME-8M-DS-24V-K-2,5-OE
				5.0	★ 543863	SME-8M-DS-24V-K-5,0-OE
			Cable, 2-wire	2.5	★ 543872	SME-8M-ZS-24V-K-2,5-OE
			Plug connector M8x1, 3-pin	0.3	★ 543861	SME-8M-DS-24V-K-0,3-M8D
	Inserted in the slot lengthwise, flush with the cylinder profile	Contacting	Cable, 3-wire	2.5	150855	SME-8-K-LED-24
			Plug connector M8x1, 3-pin	0.3	150857	SME-8-S-LED-24

Festo core product range



- ★ Generally ready for shipping ex works in 24 hours
- ☆ Generally ready for shipping ex works in 5 days

# Twin-piston semi-rotary drives DRRD

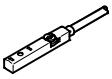
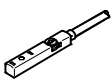
Accessories

Proximity sensor for size 16 ... 63						
Ordering data – Proximity sensors for T-slot, inductive						Technical data → Internet: sies
	Type of mounting	Switching output	Electrical connection	Cable length [m]	Part No.	Type
<b>N/O contact</b>						
	Insertable in the slot from above, flush with the cylinder profile	PNP	Cable, 3-wire	7.5	551386	SIES-8M-PS-24V-K-7,5-OE
			Plug connector M8x1, 3-pin	0.3	551387	SIES-8M-PS-24V-K-0,3-M8D
		NPN	Cable, 3-wire	7.5	551396	SIES-8M-NS-24V-K-7,5-OE
			Plug connector M8x1, 3-pin	0.3	551397	SIES-8M-NS-24V-K-0,3-M8D
<b>N/C contact</b>						
	Insertable in the slot from above, flush with the cylinder profile	PNP	Cable, 3-wire	7.5	551391	SIES-8M-PO-24V-K-7,5-OE
			Plug connector M8x1, 3-pin	0.3	551392	SIES-8M-PO-24V-K-0,3-M8D
		NPN	Cable, 3-wire	7.5	551401	SIES-8M-NO-24V-K-7,5-OE
			Plug connector M8x1, 3-pin	0.3	551402	SIES-8M-NO-24V-K-0,3-M8D

-  - Note  
 The inductive proximity sensors SIES can only be used in combination with the sensing kit DASI-...-KT.

Ordering data – Connecting cables					Technical data → Internet: nebu
	Electrical connection, left	Electrical connection, right	Cable length [m]	Part No.	Type
	Straight socket, M8x1, 3-pin	Cable, open end, 3-wire	2.5	★ 541333	NEBU-M8G3-K-2.5-LE3
			5	★ 541334	NEBU-M8G3-K-5-LE3
	Angled socket, M8x1, 3-pin	Cable, open end, 3-wire	2.5	★ 541338	NEBU-M8W3-K-2.5-LE3
			5	★ 541341	NEBU-M8W3-K-5-LE3

Festo core product range

- ★ Generally ready for shipping ex works in 24 hours
- ☆ Generally ready for shipping ex works in 5 days

# Twin-piston semi-rotary drives DRRD

Accessories

FESTO

## Position sensor for size 16 ... 63

The position transmitter continuously senses the position of the piston.

It has an analogue output with an output signal in proportion to the piston position.

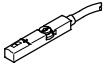
Ordering data – Position sensors for T-slot					Technical data → Internet: position sensor	
	Type of mounting	Electrical connection, outlet direction	Analogue output [V]	Cable length [m]	Part No.	Type
	Insertable in slot from above	Plug M8x1, 4-pin, in-line	0 ... 10	0.3	553744	SMAT-8M-U-E-0,3-M8D

Size	16	20	25	32	35	40	50	63
Position measuring range for SMAT-8M [°]	151	120	183	159	185	132	82	64

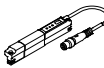
	Position measuring range	Type of mounting	Electrical connection	Analogue output [mA]	Cable length [m]	Part No.	Type
	0 ... 50	Insertable in slot from above	Plug M8x1, 4-pin, in-line	4 ... 20	0.3	1531265	SDAT-MHS-M50-1L-SA-E-Q3-M8
	0 ... 80					1531266	SDAT-MHS-M80-1L-SA-E-Q3-M8
	0 ... 100					1531267	SDAT-MHS-M100-1L-SA-E-Q3-M8
	0 ... 125					1531268	SDAT-MHS-M125-1L-SA-E-Q3-M8
	0 ... 160					1531269	SDAT-MHS-M160-1L-SA-E-Q3-M8

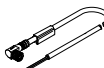
Ordering data – Connecting cables				Technical data → Internet: nebu	
	Electrical connection, left	Electrical connection, right	Cable length [m]	Part No.	Type
	Straight socket, M8x1, 4-pin	Cable, open end, 4-wire	2.5	541342	NEBU-M8G4-K-2.5-LE4
			5	541343	NEBU-M8G4-K-5-LE4
	Angled socket, M8x1, 4-pin	Cable, open end, 4-wire	2.5	541344	NEBU-M8W4-K-2.5-LE4
			5	541345	NEBU-M8W4-K-5-LE4

# Twin-piston semi-rotary drives DRRD

Accessories

FESTO

## Wiring of the proximity sensor in combination with the energy throughfeed

Size 16/20

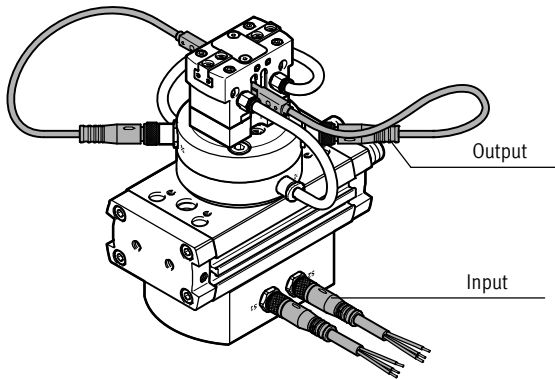

Sizes 25/32/35

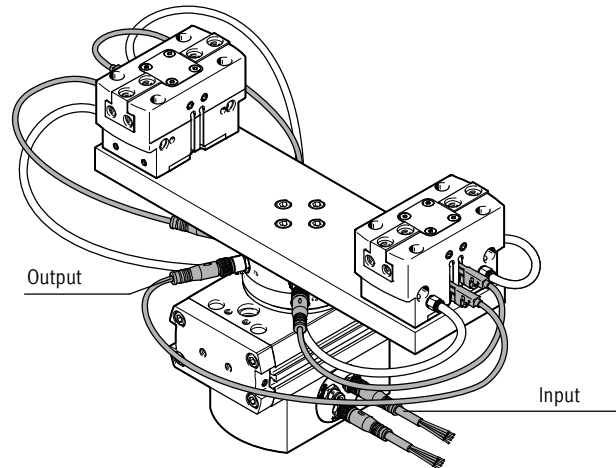

Size 40/50/63

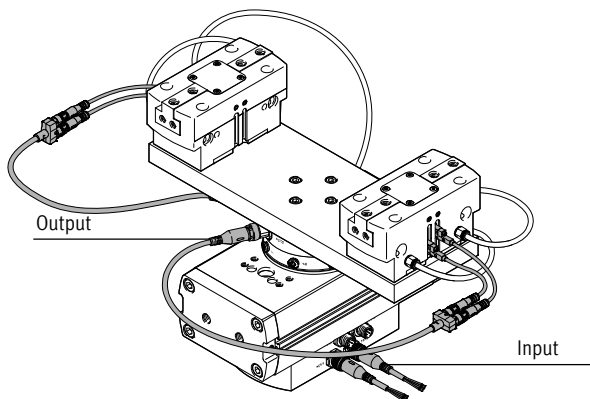



Note

Proximity sensors with plug connectors must be used for attachments (e.g. grippers) at the output. On sizes 16 ... 35 these can be connected directly to the energy throughfeed

module.

For sizes 40 ... 63, the proximity sensor must be connected to the energy throughfeed module through a Y-distributor.

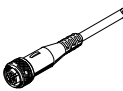
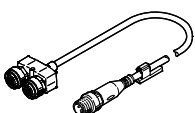
Ordering data				Technical data → Internet: nebu	
	Electrical connection, left	Electrical connection, right	Cable length [m]	Part No.	Type
<b>Input – Connecting cable</b>					
Size 16/20					
	Straight socket, M8x1, 3-pin	Cable, open end, 3-wire	2.5	★ 541333	NEBU-M8G3-K-2.5-LE3
	Straight socket, M8x1, 3-pin	Cable, open end, 3-wire	5	★ 541334	NEBU-M8G3-K-5-LE3
Size 25/32/35					
	Straight socket, M8x1, 4-pin	Cable, open end, 4-wire	2.5	541342	NEBU-M8G4-K-2.5-LE4
	Straight socket, M8x1, 4-pin	Cable, open end, 4-wire	5	541343	NEBU-M8G4-K-5-LE4
Size 40/50/63					
	Straight socket, M12x1, 5-pin	Cable, open end, 4-wire	2.5	★ 550326	NEBU-M12G5-K-2.5-LE4
	Straight socket, M12x1, 5-pin	Cable, open end, 4-wire	5	★ 541328	NEBU-M12G5-K-5-LE4
<b>Output – Y-distributor</b>					
Size 40/50/63					
	Straight plug, M12x1, 4-pin	2x straight sockets, M8x1, 3-pin	0.5 <sup>1)</sup>	8032867	NEBU-L2R1-V1-M8G3-U-M12G4-0.5R
1) Cable lengths from 0.3 m to 30 m available → Internet: nedy					

Festo core product range

- ★ Generally ready for shipping ex works in 24 hours
- ☆ Generally ready for shipping ex works in 5 days

# Twin-piston semi-rotary drives DRRD

Accessories

FESTO

## Setting the swivel speed

Basic drive and intermediate position module must only be operated with controlled air flow. The throttle valves should be connected as close as possible to the semi-rotary drive (e.g. one-way flow control valve GRLA-...) → table below.

In the event of pressure failure, the payload may hit an end position in an uncontrolled manner. In order to prevent this, piloted check valves HGL or an air reservoir VZS are recommended.

## Ordering data – Accessories for basic drive

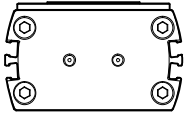

	For size	Description	Weight [g]	Part No.	Type	PU <sup>1)</sup>
<b>One-way flow control valve GRLA</b>						
	16 <sup>2)</sup> , 20, 25	• To set the swivel speed	14	★ 197576	GRLA-M5-QS-3-RS-D	1
			14	★ 197577	GRLA-M5-QS-4-RS-D	
	32, 35, 40		30	151169	GRLA-1/8-RS-B	
			59	151175	GRLA-1/4-RS-B	
	63	97	151178	GRLA-3/8-B		

1) Packaging unit

## Ordering data – Accessories for intermediate position module (PS1)

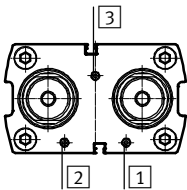

The following movements are adjusted using the supply ports **1** and **2**: end position → intermediate position.  
Both directions can be adjusted separately from each other.  
The following movement is set via supply port **3**.  
Intermediate position → end position  
Both directions are set simultaneously.

	For size	Description	Weight [g]	Part No.	Type	PU <sup>1)</sup>
<b>One-way flow control valve GRLA</b>						
	16 <sup>2)</sup> , 20, 25, 32, 35, 40	• To set the swivel speed from the intermediate position	14	★ 197576	GRLA-M5-QS-3-RS-D	1
			14	★ 197577	GRLA-M5-QS-4-RS-D	
	30		151169	GRLA-1/8-RS-B		
<b>Check valve HGL</b>						
	20, 25, 32, 35, 40	• For cushioning the payload in the event of a loss of compressed air	21	★ 530029	HGL-M5-B	1
			21	★ 530038	HGL-M5-QS-4	
	50		26	543253	HGL-1/8-1/8-B	
			21	★ 530030	HGL-1/8-B	
<b>Air reservoir VZS</b>						
	16, 20, 25, 32, 35, 40, 50	• For cushioning the payload in the event of a loss of compressed air	8600	192161	VZS-20-B	1

1) Packaging unit

2) Strongly recommended for this size

Festo core product range

★ Generally ready for shipping ex works in 24 hours

☆ Generally ready for shipping ex works in 5 days



# Twin-piston semi-rotary drives DRRD

Accessories

FESTO

Adapter kit  
DHAA

Materials:  
Wrought aluminium alloy  
Free of copper and PTFE  
RoHS compliant

 Note  
The kit includes the individual mounting interface as well as the necessary mounting material.

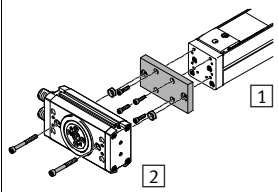
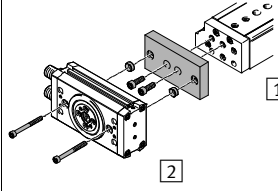
Permissible drive/drive combinations with adapter kit				Download CAD data → <a href="http://www.festo.com">www.festo.com</a>		
Combination	[1] Drive	[2] Drive	Adapter kit			Required quantity
	Size	Size	CRC <sup>1)</sup>	Part No.	Type	
DGEA/DRRD	DGEA	DRRD	DHAA			
	18	16	2	1675259	DHAA-D-E2-18-Q11-16	1
	18, 25	20		1679833	DHAA-D-E2-18/25-Q11-20	
	25	25		1696421	DHAA-D-E2-25-Q11-25	
	25	32		1702297	DHAA-D-E2-25-Q11-32	
	40	32		1706071	DHAA-D-E2-40-Q11-32	
	40	35		1706503	DHAA-D-E2-40-Q11-35	
	40	40		1706822	DHAA-D-E2-40-Q11-40	
	DGEA	DRRD-...P...E... <sup>2)</sup>		DHAA		
	18	16	2	2328624	DHAA-D-E2-18-Q11-16-E	1
	18, 25	20		2328779	DHAA-D-E2-18/25-Q11-20-E	
	25	25		2328793	DHAA-D-E2-25-Q11-25-E	
	25	32		2328805	DHAA-D-E2-25-Q11-32-E	
	40	32		2328816	DHAA-D-E2-40-Q11-32-E	
	40	35		2328827	DHAA-D-E2-40-Q11-35-E	
40	40	2328838		DHAA-D-E2-40-Q11-40-E		
DGSL/DRRD	DGSL	DRRD	DHAA			
	4	8	2	2767489	DHAA-D-G6-4-Q11-8	1
	6	8		2762930	DHAA-D-G6-6-Q11-8	
	8, 10	10		2737394	DHAA-D-G6-8/10-Q11-10	
	12, 16	10		2737247	DHAA-D-G6-12/16-Q11-10	
	8, 10	12		2736429	DHAA-D-G6-8/10-Q11-12	
	12	12		2782718	DHAA-D-G6-12-Q11-12	
	16	12		2734418	DHAA-D-G6-16-Q11-12	
	20	16		1917841	DHAA-D-G6-20-Q11-16	
	20, 25	20		1916912	DHAA-D-G6-20/25-Q11-20	
	25	25		1707360	DHAA-D-G6-25-Q11-25	
	DGSL	DRRD-...P...E... <sup>2)</sup>	DHAA			
	20	16	2	2332271	DHAA-D-G6-20-Q11-16-E	1
	20, 25	20		2332452	DHAA-D-G6-20/25-Q11-20-E	
	25	25		2332584	DHAA-D-G6-25-Q11-25-E	

1) Corrosion resistance class CRC 2 to Festo standard FN 940070  
Moderate corrosion stress. Indoor applications in which condensation may occur. External visible parts with primarily decorative requirements for the surface and which are in direct contact with the ambient atmosphere typical for industrial applications.

2) With energy throughfeed

# Twin-piston semi-rotary drives DRRD

Accessories



## Adapter kit DHAA

Materials:  
Wrought aluminium alloy  
Free of copper and PTFE  
RoHS compliant

 Note  
The kit includes the individual mounting interface as well as the necessary mounting material.

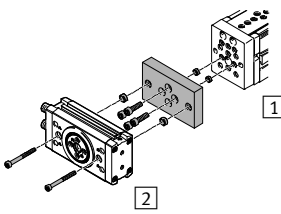
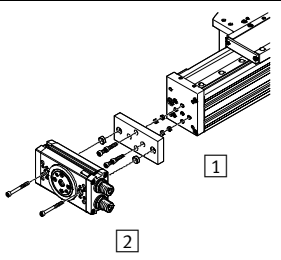
Permissible drive/drive combinations with adapter kit			Download CAD data → <a href="http://www.festo.com">www.festo.com</a>				
Combination	1 Drive	2 Drive	Adapter kit			Required quantity	
	Size	Size	CRC <sup>1)</sup>	Part No.	Type		
	EGSL	DRRD	DHAA			1	
	35	8	2	2730033	DHAA-D-E8-35-Q11-8		
	35	10		2729506	DHAA-D-E8-35-Q11-10		
	45	10		2728486	DHAA-D-E8-45-Q11-10		
	35	12		2719384	DHAA-D-E8-35-Q11-12		
	45, 55	12		2715152	DHAA-D-E8-45/55-Q11-12		
	55	16		1926914	DHAA-D-E8-55-Q11-16		
	75	16		1928306	DHAA-D-E8-75-Q11-16		
	75	20		1930038	DHAA-D-E8-75-Q11-20		
	EGSL	DRRD-...-P...E... <sup>2)</sup>		DHAA			1
	55	16		2	2279410	DHAA-D-E8-55-Q11-16-E	
	75	16	2279453		DHAA-D-E8-75-Q11-16-E		
	75	20	2279473		DHAA-D-E8-75-Q11-20-E		
	ELCC	DRRD	DHAA			1	
	60	10	2	2737394	DHAA-D-G6-8/10-Q11-10		
	60	12		2736429	DHAA-D-G6-8/10-Q11-12		
	60	16		1675259	DHAA-D-E2-18-Q11-16		
	60, 70	20		1679833	DHAA-D-E2-18/25-Q11-20		
	60, 70	25		1696421	DHAA-D-E2-25-Q11-25		
	70	32		1702297	DHAA-D-E2-25-Q11-32		
	70, 90	32		5154625	DHAA-D-E21-70...110-Q11-32		
	70, 90	35		5154627	DHAA-D-E21-70...110-Q11-35		
	90, 110	40		5154629	DHAA-D-E21-70...110-Q11-40		
	90, 110	50		5154639	DHAA-D-E21-70...110-Q11-50		
	110	63		5154642	DHAA-D-E21-70...110-Q11-63		
	ELCC	DRRD-...-P...E... <sup>2)</sup>		DHAA			1
	60	16		2	2328624	DHAA-D-E2-18-Q11-16-E	
	60, 70	20	2328779		DHAA-D-E2-18/25-Q11-20-E		
	60, 70	25	2328793		DHAA-D-E2-25-Q11-25-E		
	70	32	2328805		DHAA-D-E2-25-Q11-32-E		
	70, 90	32	5154626		DHAA-D-E21-70...110-Q11-32-E		
	70, 90	35	5154628		DHAA-D-E21-70...110-Q11-35-E		
90, 110	40	5154630	DHAA-D-E21-70...110-Q11-40-E				
90, 110	50	5154640	DHAA-D-E21-70...110-Q11-50-E				
110	63	5154643	DHAA-D-E21-70...110-Q11-63-E				

- Corrosion resistance class CRC 2 to Festo standard FN 940070  
Moderate corrosion stress. Indoor applications in which condensation may occur. External visible parts with primarily decorative requirements for the surface and which are in direct contact with the ambient atmosphere typical for industrial applications.
- With energy throughfeed
- The centring sleeves for attaching to the adapter kit HAPG-72-B are not required.

# Twin-piston semi-rotary drives DRRD

Accessories

FESTO

**Adapter kit**  
DHAA, HAPG

Materials:  
Wrought aluminium alloy  
Free of copper and PTFE  
RoHS compliant

 Note  
The kit includes the individual mounting interface as well as the necessary mounting material.

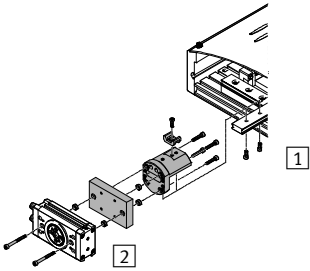
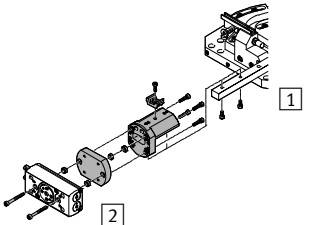
Permissible drive/drive combinations with adapter kit						Download CAD data → <a href="http://www.festo.com">www.festo.com</a>
Combination	1	2	Adapter kit			Required quantity
	Drive	Drive	CRC <sup>1)</sup>	Part No.	Type	
	HSP	DRRD	DHAA			1
	12	8	2	2786084	DHAA-D-H4-12-Q11-8	
			-	540881	HAPG-70-B	
	16	10	2	2785801	DHAA-D-H4/H5-12/16-Q11-10	
			-	540882	HAPG-71-B	
	16	12	2	2784113	DHAA-D-H4/H5-16/25-Q11-12	
			-	540882	HAPG-71-B	
	25	12	2	2784113	DHAA-D-H4/H5-16/25-Q11-12	
			-	540883	HAPG-72-B <sup>3)</sup>	
	25	16	2	1919910	DHAA-D-H4-25-Q11-16	
		-	540883	HAPG-72-B <sup>3)</sup>		
HSP	DRRD-...-P...E... <sup>2)</sup>	DHAA			1	
25	16	2	2284940	DHAA-D-H4-25-Q11-16-E		
		-	540883	HAPG-72-B <sup>3)</sup>		
	HSW	DRRD	DHAA			1
	10	8	2	2789655	DHAA-D-H5-10-Q11-8	
			-	540249	HAPG-69	
	12	8	2	2788114	DHAA-D-H5-12-Q11-8	
			-	540882	HAPG-71-B	
	12	10	2	2785801	DHAA-D-H4/H5-12/16-Q11-10	
			-	540882	HAPG-71-B	
	16	10	2	2785801	DHAA-D-H4/H5-12/16-Q11-10	
		-	540882	HAPG-71-B		
16	12	2	2784113	DHAA-D-H4/H5-16/25-Q11-12		
		-	540882	HAPG-71-B		

- 1) Corrosion resistance class CRC 2 to Festo standard FN 940070  
Moderate corrosion stress. Indoor applications in which condensation may occur. External visible parts with primarily decorative requirements for the surface and which are in direct contact with the ambient atmosphere typical for industrial applications.
- 2) With energy throughfeed
- 3) The centring sleeves for attaching to the adapter kit HAPG-72-B are not required.

# Festo - Your Partner in Automation



**1 Festo Inc.**  
5300 Explorer Drive  
Mississauga, ON L4W 5G4  
Canada

**Festo Customer Interaction Center**  
Tel: 1 877 463 3786  
Fax: 1 877 393 3786  
Email: [customer.service.ca@festo.com](mailto:customer.service.ca@festo.com)



**2 Festo Pneumatic**  
Av. Ceylán 3,  
Col. Tequesquináhuac  
54020 Tlalneantla,  
Estado de México

**Multinational Contact Center**  
01 800 337 8669  
[ventas.mexico@festo.com](mailto:ventas.mexico@festo.com)



**3 Festo Corporation**  
1377 Motor Parkway  
Suite 310  
Islandia, NY 11749

**Festo Customer Interaction Center**  
1 800 993 3786  
1 800 963 3786  
[customer.service.us@festo.com](mailto:customer.service.us@festo.com)



**4 Regional Service Center**  
7777 Columbia Road  
Mason, OH 45040

Connect with us



[www.festo.com/socialmedia](http://www.festo.com/socialmedia)



[www.festo.com](http://www.festo.com)

Subject to change