

ZSM2101-103126 (Order no. 103126)

ZSM, LED, + and – buttons, vibration motor, stop command device, key-operated rotary switch

- ▶ 3-stage function
- ▶ Stop command device
- ▶ Vibration signal
- ▶ LED indicator
- ▶ + and – buttons
- ▶ Key-operated rotary switch
- ▶ Straight connecting cable, 5 m



3-stage function

Enabling function is active only in the second stage (center position, actuating point). If the pushbutton is released or pushed further (panic function), the enabling is removed (dependent on the wiring, see function sequence).

Stop command device

Dual-channel emergency stop device (red, with pull-to-reset and turn-to-reset button) on the switch housing, for different wiring concepts.

Lower position, protected by anti-kink strain relief in case of a fall.

Vibration signal

The vibration signal is used for tactile feedback of the enabling position.

LED indicator

The LED indicator is used for visual feedback directly at the enabling switch.

+ and – buttons

These pushbuttons can be configured individually. For example, for moving axes in the positive or negative direction.

Key-operated rotary switch

For individual use, e.g. as an operating mode selector.

Cable

The high-quality connecting cables are available in a straight version.

Dimensional drawings

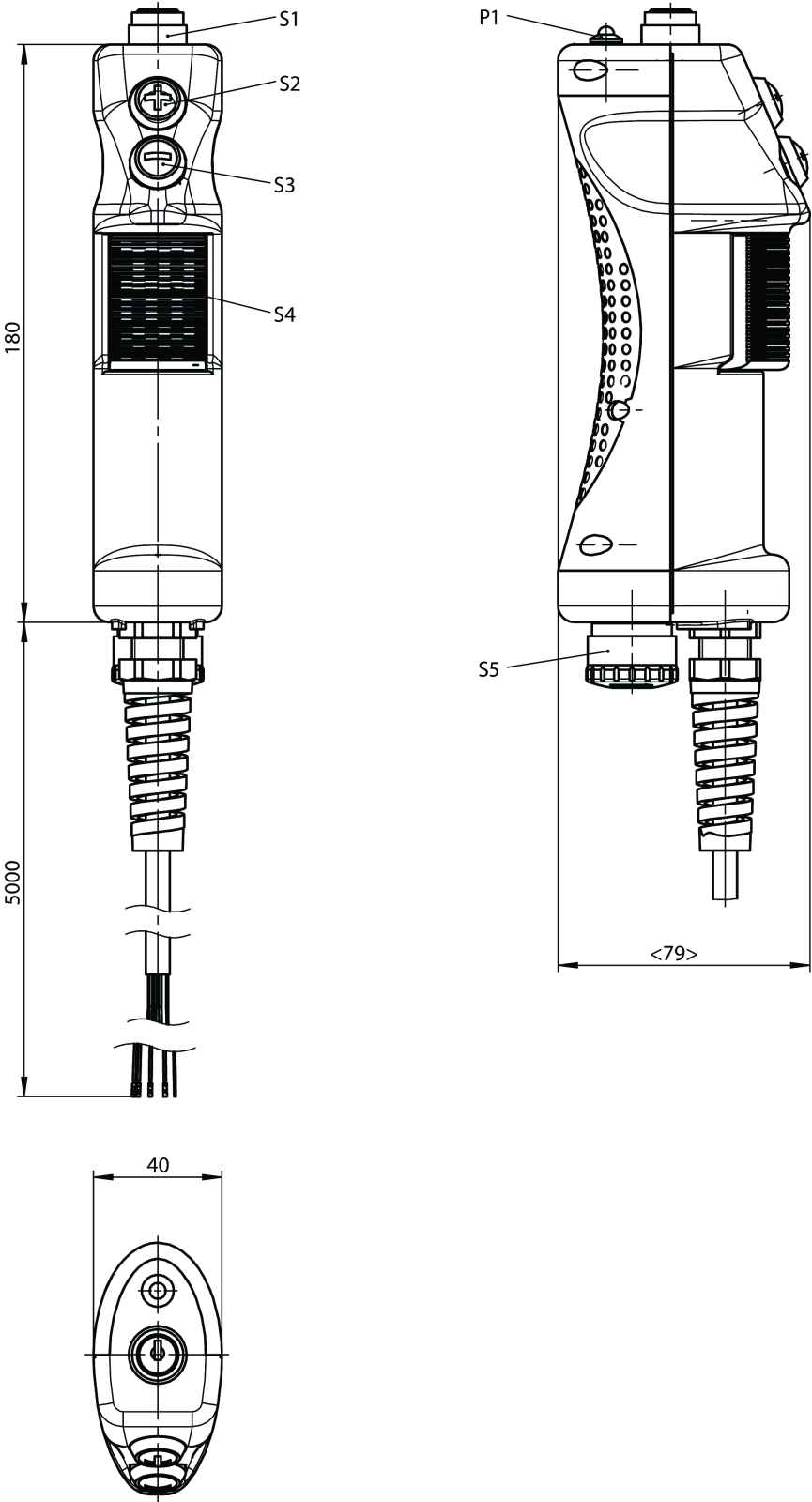

Connection examples

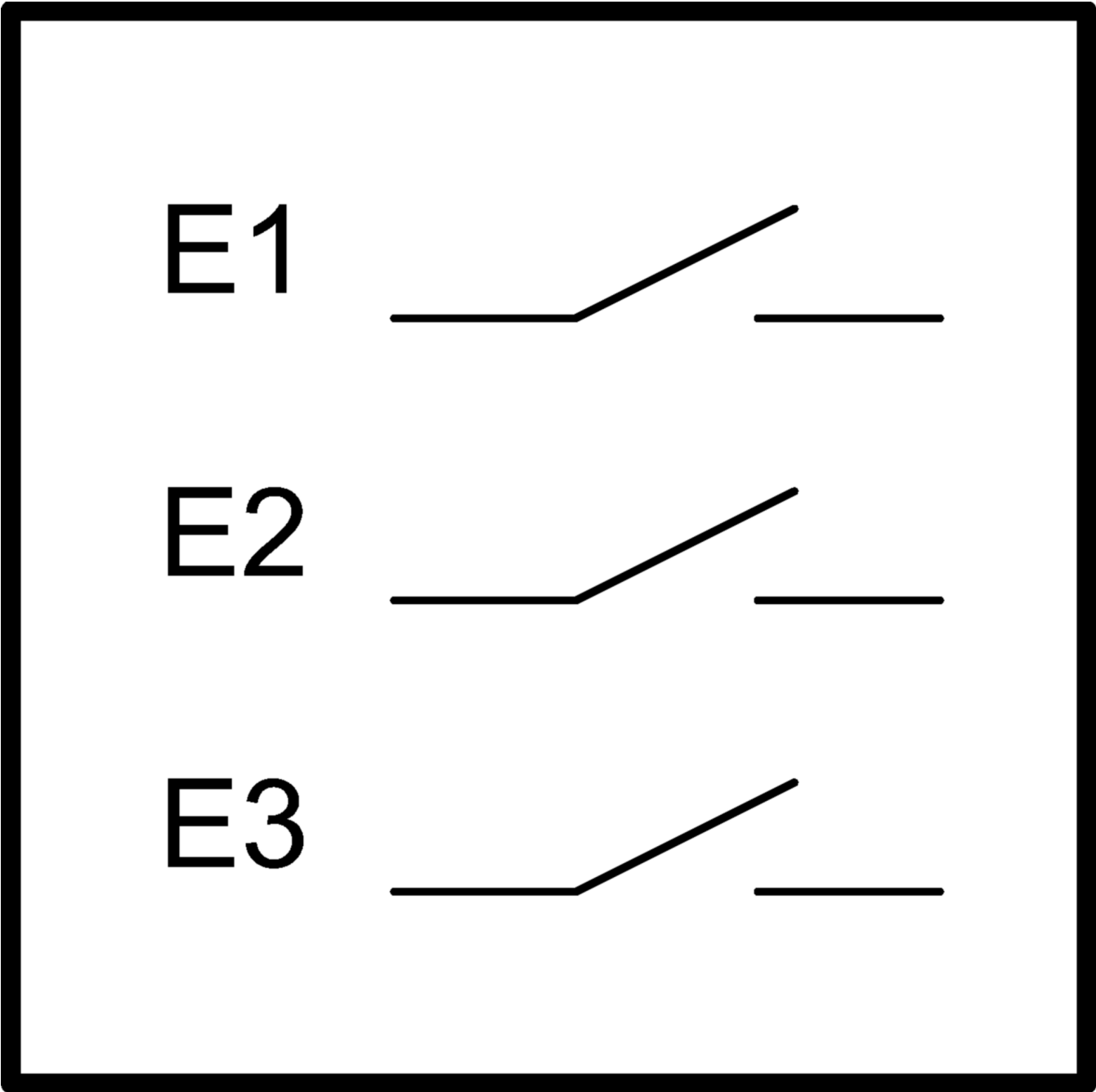

Connection examples

S1:
Schlüsselschalter
key switch

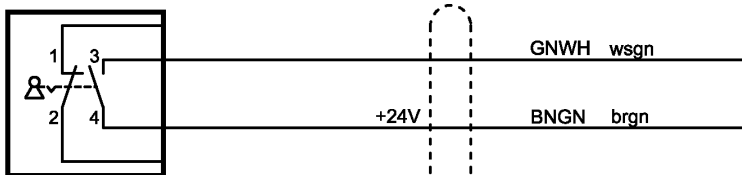

S2: "+"
Drucktaste
pushbutton

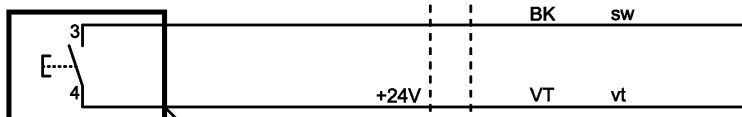

S3: "-"
Drucktaste
pushbutton

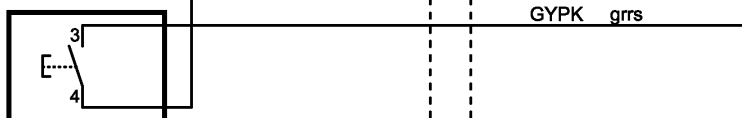

V1:
LED gelb
LED yellow

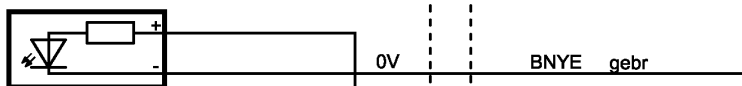

S4:
Zustimmtaster
enabling pushbutton

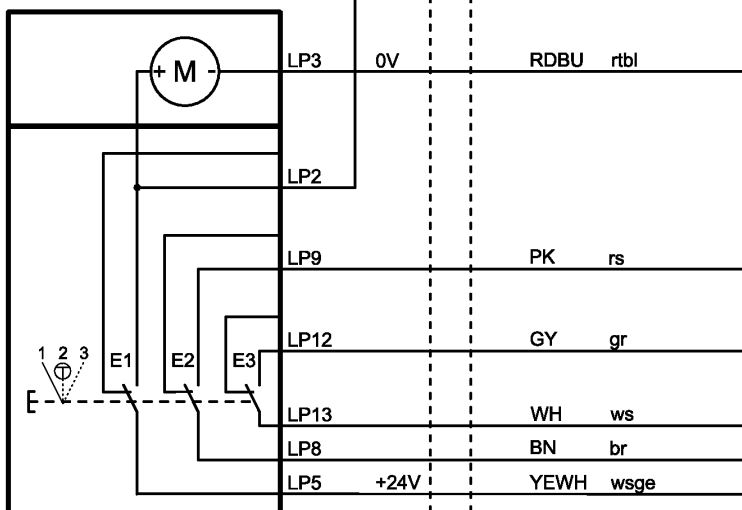
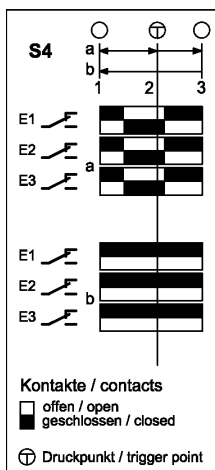

S5:
Not-Halt
emergency-stop

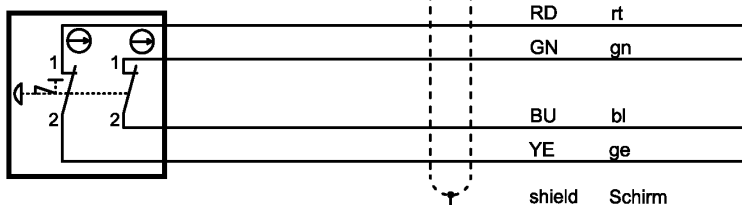

Leitung / cable:
23x0,14mm²

Connection examples

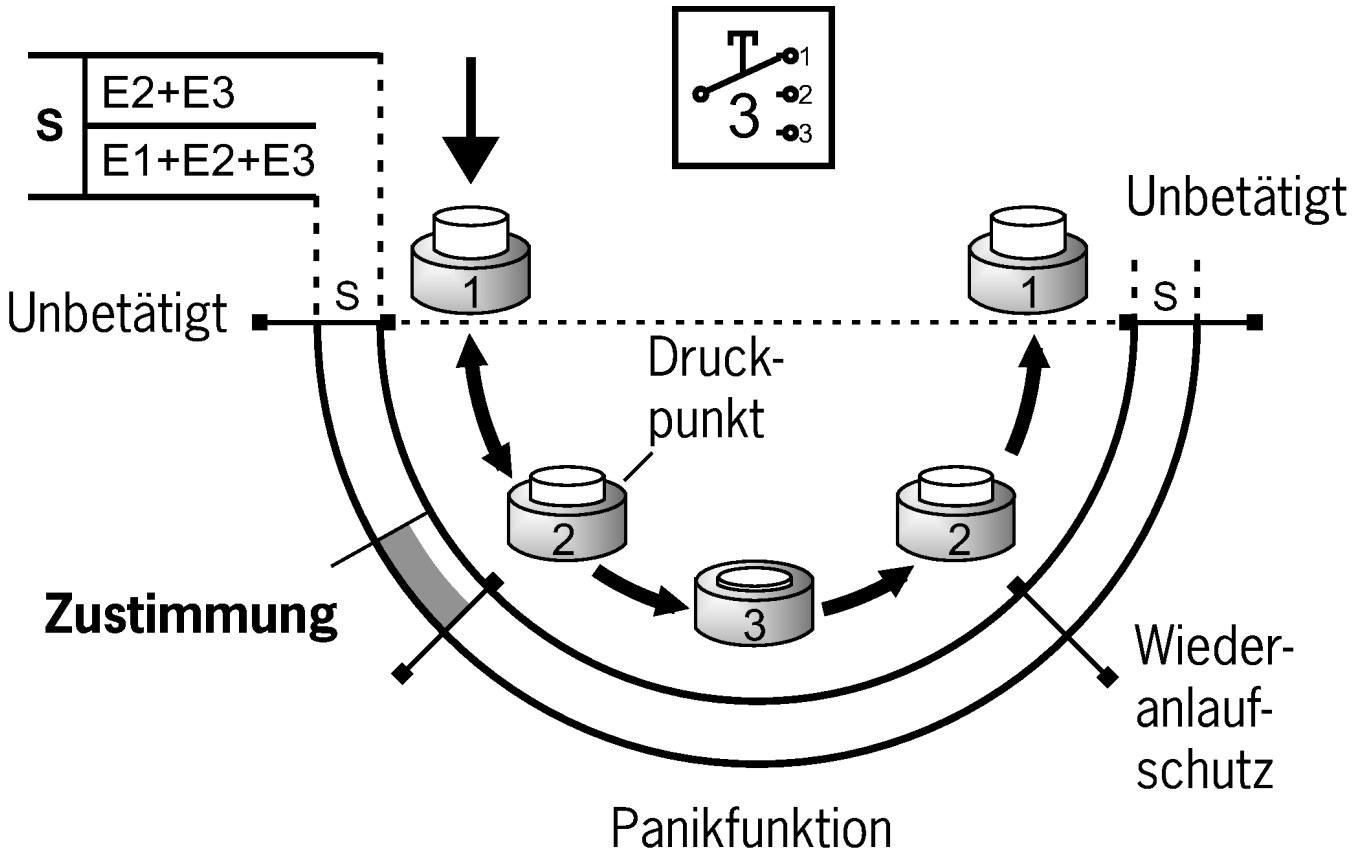

Technical data

Approvals



Operating and display elements

Item	Color	Extras	Note slide-in label	Switching element	Version	Slide-in label	Number	Designation1	LED
					+ button		1		
					- button		1		
	Yellow				LED		1		
					Emergency stop device		1		
					Key-operated rotary switch		1		
					Vibration motor		1		

Electrical connection values

Connecting cable	23x0.14 mm ² (screened)
rated conditional short-circuit current	100 A
Rated insulation voltage U _i	50 V
Rated impulse withstand voltage U _{imp}	0.5 kV
Utilization category	
	DC-13 24 V 0.01 A (For additional indicators)
	DC-13 30 V 0.1 A (For enabling switch, caution: outputs must be protected with a free-wheeling diode in case of inductive loads)
	DC-13 24 V 0.3 A (For additional controls)

Short circuit protection according to IEC 60269-1	2A gG (In case of operating voltages other than 24 V, the short circuit protection must be dimensioned accordingly and checked.)
---	---

Switching characteristics	3-stage enabling switch
---------------------------	-------------------------

Degree of contamination (external, according to EN 60947-1)	3
---	---

Mechanical values and environment

Connection type	flying lead
-----------------	-------------

Number of changeover contacts	3 (Connection as per block diagram)
-------------------------------	--

Cable length	
	straight 5 m

Mechanical life	1 x 10 ⁶
-----------------	---------------------

Switching principle	Snap-action contact element
---------------------	-----------------------------

Degree of protection	IP54
----------------------	------

Ambient temperature	-5 ... +60 °C
---------------------	---------------

Material	PA, CR, TPE (Low PAH)
----------	--------------------------

Characteristic values according to EN ISO 13849-1 and EN IEC 62061

Emergency stop

B _{10D}	0.1 x 10 ⁶
------------------	-----------------------

Enabling switch

B _{10D}	0.1 x 10 ⁶
------------------	-----------------------

Miscellaneous

in compliance with	60947-5-8
--------------------	-----------

Downloads

All documentation for this material can be found on our website:

<https://www.euchner.de/en-us/a/103126/?#downloads-tab>

Ordering data

Ordernumber	103126
Item designation	ZSM2101-103126
Gross weight	0,938kg
Customs tariff number	85371098
ECLASS	27-37-12-38 Agreement switch

Accessories

Connection material

Blanking plug RC17 for covering the flange connector RC17



096159

BLINDSTECKER 17-POL RC-17P1N8A83NN

Plug connector RC17 for connection to enabling switches, for example



096481

STECKVERBINDER 17POL RC-17P1N8A80CP

Mounting accessories

Holder for ZSM



102965

HALTER MIT MAGNET ZSM

▶ Magnet mounting



102969

HALTER ZSM

▶ Screw mounting