



Extract from our online catalogue:

nano-24/CF

Current to: 2024-07-16



nano – what’s in a name? At just 55 mm long, including plug, the nano is the shortest M12 ultrasonic sensor on the market.

## HIGHLIGHTS

- › Ultrasonic sensor in the M12 threaded sleeve
- › IO-Link interface › for support of the new industry standard
- › The total length including plug is only 55 mm
- › Improved temperature compensation › adjustment to working conditions within 45 seconds
- › UL Listed to Canadian and US safety standards

## BASICS

- › 1 Push-Pull switching output › pnp or npn basis
- › Analogue output 4–20 mA or 0–10 V
- › 2 detection ranges with a measurement range of 20 mm to 350 mm
- › microsonic Teach-in on pin 2
- › 0.069 mm resolution
- › Operating voltage 10–30 V › for use with various voltage networks

# Description

## With a housing length of only 55 mm

nano sensors with switching outputs are the smallest ultrasonic sensors inside the M12 threaded sleeve on the market. Analogue sensors are 60 mm long. nano has a 4-pole M12 circular plug and are taught via pin 2.

## For the nano sensor family

there are 2 output stages and 2 measuring ranges available:



1 Push-Pull-switching output, in pnp or npn circuitry with IO-Link interface



1 analogue output 4–20 mA or 0–10 V

## The temperature compensation

of the sensors profits from a significant improvement. The sensors reach their operating point only 45 seconds after activation of the operating voltage. We now compensate for the influence of self-heating and installation conditions. This brings improved precision shortly after activation of the supply voltage and in running operation.

## New! With the internal alignment assistance

the sensors with Push-Pull switching output can be optimally aligned to the object during installation.

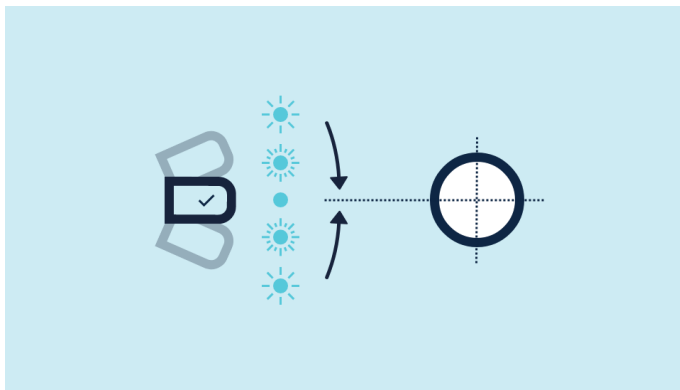

*nano sensor using alignment assistance*

## The nano sensors with switched output have three operating modes:

- › Single switching point
- › Two-way reflective barrier
- › Window mode

### Teach-in of a single switching point

- › Place object (1) to be detected at the desired distance
- › Apply  $+U_B$  to pin 2 for about 3 seconds
- › Then apply  $+U_B$  to pin 2 again for about 1 second

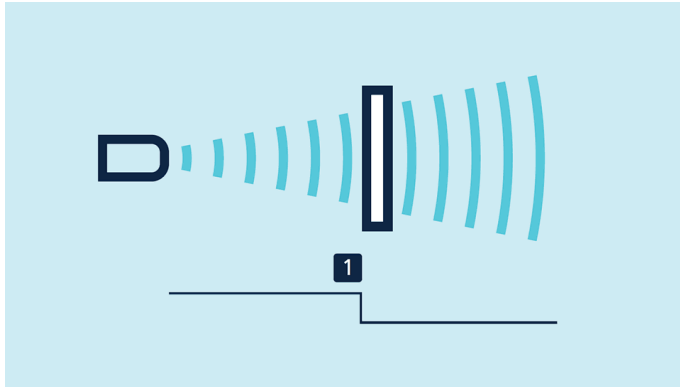

*Teach-in of a switching point*

### Teach-in of a two-way reflective barrier

with a fixed mounted reflector.

- › Apply  $+U_B$  to pin 2 for about 3 seconds
- › Then apply  $+U_B$  to pin 2 again for about 10 second

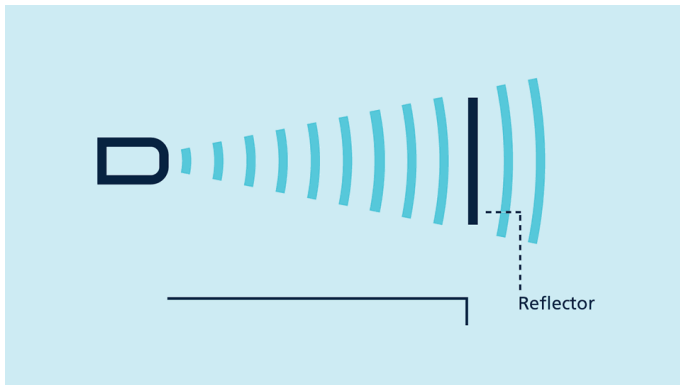

*Teach-in of a two-way reflective barrier*

### To set a window with two switching points

- › Place object to the sensor-close window limit (1)
- › Apply  $+U_B$  to pin 2 for about 3 seconds until both LEDs flash
- › Then move the object to the sensor-distant window limit (2)
- › Then apply  $+U_B$  to pin 2 again for about 1 second until LED2 extinguishes

### For setting an analogue output

- › initially position the object to be detected on the sensor-close window limit (1)

- › Apply  $+U_B$  to pin 2 for about 3 seconds until both LEDs flash
- › Move the object to the sensor-distant window limit (2)
- › Then apply  $+U_B$  to pin 2 again for about 1 second

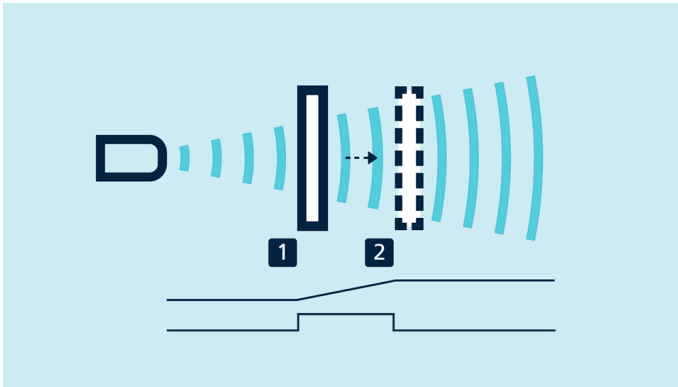

*Teach-in of an analogue characteristic or of a window with two switching points*

### NCC/NOG

and rising/falling analogue characteristic can also be set via pin 2.

### One green and one yellow LED

indicate the state of the output and support microsonic Teach-in.

### IO-Link integrated

in version 1.1.2 for sensors with Push-Pull output. The **nano-15/CF** and **nano-24/CF** support the Smart Sensor Profile, which creates more transparency between IO-Link devices.

# nano-24/CF

## scale drawing

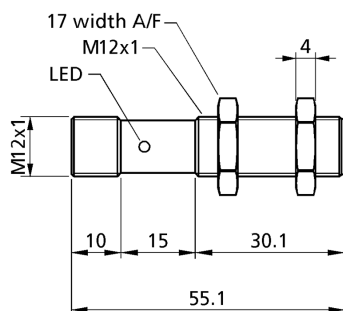

## detection zone

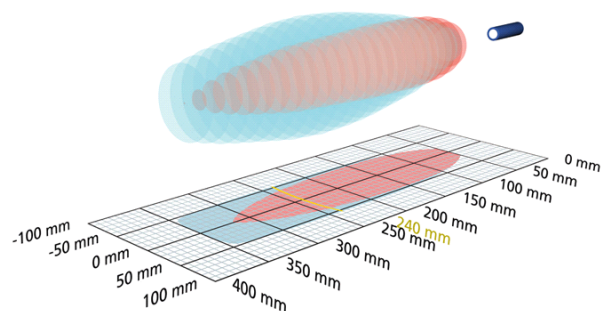

1 x Push-Pull



measuring range	40 - 350 mm
design	cylindrical M12
operating mode	IO-Link proximity switch/reflective mode reflective barrier window mode
particularities	narrow sound field IO-Link version 1.1 Smart Sensor Profile UL Listed

## ultrasonic-specific

means of measurement	echo propagation time measurement
transducer frequency	500 kHz
blind zone	40 mm
operating range	240 mm
maximum range	350 mm
resolution	0.10 mm
reproducibility	± 0.15 %
accuracy	± 1 % (temperature drift internally compensated)

## electrical data

operating voltage $U_b$	10 - 30 V d.c., reverse polarity protection
voltage ripple	± 10 %
no-load current consumption	≤ 40 mA
type of connection	4-pin M12 initiator plug

# nano-24/CF

## outputs

output 1	switching output Push-Pull, $U_B=3\text{ V}$ , $-U_B+3\text{ V}$ , $I_{\max} = 100\text{ mA}$ NOC/NCC adjustable, short-circuit-proof
switching hysteresis	3 mm
switching frequency	20 Hz
response time	40 ms
delay prior to availability	< 300 ms

## inputs

input 1	com input synchronisation input teach-in input
---------	--

## IO-Link

product name	nano-24/CF
product ID	34021
SIO mode support	yes
COM mode	COM2 (38,4 kBaud)
min. cycle time	10 ms
format of process data	4 Byte
content of process data	Bit 0: initial state Pin 4; Bit 8-15: scale (Int. 8); Bit 16-31: measured value (Int. 16)
ISDU paramter	Identification, measuring configuration, switched output, filter, temperature compensation, operation
system commands	SP1 Teach-in, SP2 Teach-in, factory settings
Smart Sensor Profile	yes
IODD version	IODD version 1.1.2

## housing

material	brass sleeve, nickel-plated, plastic parts, PBT
ultrasonic transducer	polyurethane foam, epoxy resin with glass contents
class of protection to EN 60529	IP 67
operating temperature	-25°C to +70°C
storage temperature	-40°C to +85°C
weight	15 g

# nano-24/CF

## technical features/characteristics

temperature compensation	yes
scope for settings	Teach-in via com input on pin 2 LCA-2 with LinkControl IO-Link
Synchronisation	yes
multiplex	yes
indicators	LED grün, LED gelb
particularities	narrow sound field IO-Link version 1.1 Smart Sensor Profile UL Listed

## pin assignment

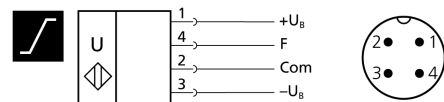

order no.

**nano-24/CF**

The content of this document is subject to technical changes.  
Specifications in this document are presented in a descriptive way  
only. They do not warrant any product features.