



Extract from our online catalogue:

sks-15/D

Current to: 2024-02-26



Our "smallest sensor": The sks sensor in cuboidal housing.

HIGHLIGHTS

- › Very small housing dimensions with two M3 threaded sleeves
- › Installation-compatible with many optical sensors › a true alternative for critical applications
- › IO-Link interface › for support of the new industry standard
- › Optionally with SoundPipe sks1 waveguide attachment
- › Improved temperature compensation › adjustment to working conditions within 45 seconds
- › Smart Sensor Profiles › more transparency between IO-Link Devices
- › UL Listed to Canadian and US safety standards

BASICS

- › 1 switching output in pnp or npn variant
- › 1 Push-Pull switching output › pnp or npn basis
- › Analogue output 4-20 mA or 0-10 V
- › microsonic Teach-in using a button
- › 0.1 mm resolution
- › 20–30 V operating voltage

Description

The sks sensors

are the smallest cuboidal ultrasonic sensors from microsonic and feature a housing design reduced by 33% compared to the zws sensors.

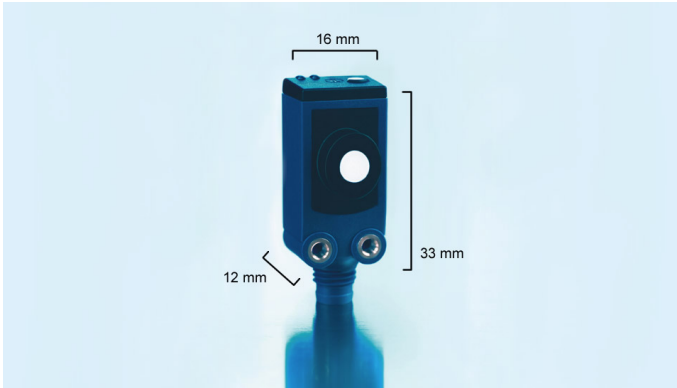

The miniature housing of the sks ultrasonic sensor fits in constricted installation locations e.g. for sampling conductor boards and wafer in the electronics industry, for presence checks on conveyor bands or fill-level measurement in small containers. When capacitive or optical sensors come up against their physical limits, installation compatibility of ultrasonic sensors with many optical sensors enable their deployment: simply secured with two M3 screw sockets.

For the sks sensor range

two output versions are available:



1 switching output, optionally in pnp-, npn- or Push-Pull circuitry



1 analogue output 4–20 mA or 0–10 V

The temperature compensation

of the analogue sensors profits from a significant improvement. The sensors reach their operating point only 45 seconds after activation of the operating voltage. We now compensate for the influence of self-heating and installation conditions. This brings improved precision shortly after activation of the supply voltage and in running operation.

The Teach-in button

on the top of the sensor allows for the convenient configuration of the desired switching distance and operating mode.

Two LEDs

show the operating state of the sensor.

The sks sensor with switching output has three operating modes:

- › Single switching point,
- › Two-way reflective barrier and
- › Window mode

permit configuration using the usual microsonic Teach-in procedure.

The switched output is set by:

positioning the object to be detected within the desired distance (1) to the sensor, pressing the button for approx. 3 seconds and then pressing it once more for approx. 1 second. Ready.

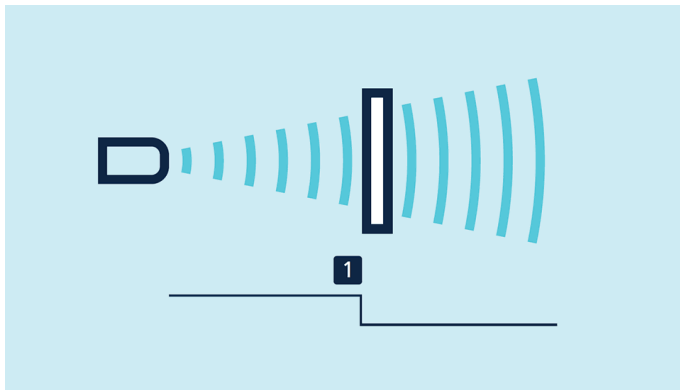

Teach-in of a switching point

A two-way reflective barrier

can be set up with the help of a permanently mounted reflector by mounting the sks sensor and the reflector. Then press the button for approx. 3 seconds and then pressing it once more for approx. 10 seconds. Now, the two-way reflective barrier has been set.

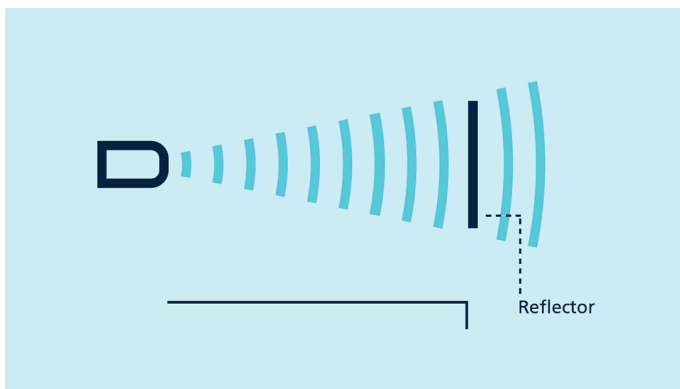

Teach-in of a two-way reflective barrier

Set a window

by initially positioning the object to be detected on the sensor-close window limit (1), pressing the button for approx. 3 seconds, shifting the object to the sensor-distant window limit and pressing the button once more for approx. 1 second.
Ready.

Set the analogue output

by initially positioning the object to be detected on the sensor-close window limit (1), pressing the button for approx. 3 seconds, shifting the object to the sensor-distant window limit and pressing the button once more for approx. 1 second.
Ready.

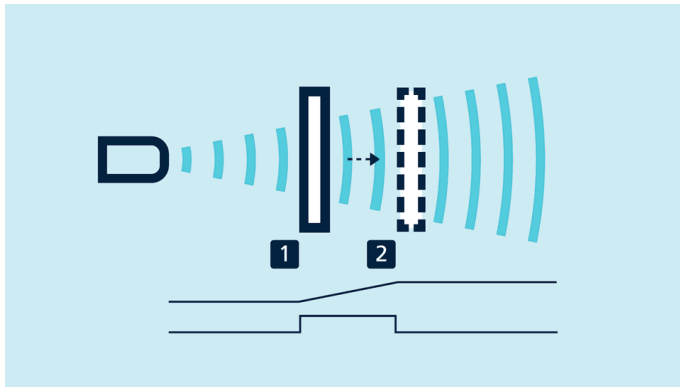

Teach-in of a window with two switching points or of an analogue characteristic

NCC/NOG

and rising/ falling analogue characteristic curve can also be set using the button.

SoundPipe sks1

intensively bundles the sound field and allows measurements in openings with small diameters. The **SoundPipe sks1** (accessory) is pushed on the transducer of the sks.

IO-Link integrated

in version 1.1 for sensors with Push-Pull output. The **sks-15/CF/A** supports the Smart Sensor Profile.

sks-15/D

scale drawing

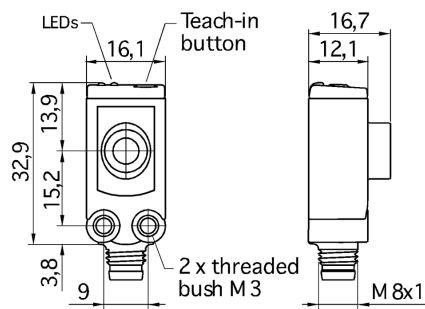

detection zone

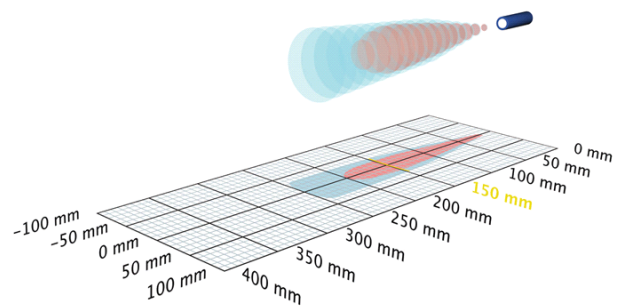

1 x pnp



250 mm

measuring range	20 - 250 mm
design	cuboidal
operating mode	proximity switch/reflective mode reflective barrier window mode
particularities	minimum cuboidal design narrow sound field

ultrasonic-specific

means of measurement	echo propagation time measurement
transducer frequency	380 kHz
blind zone	20 mm
operating range	150 mm
maximum range	250 mm
resolution	0.10 mm
reproducibility	± 0.15 %
accuracy	temperature drift 0.17 %/K

electrical data

operating voltage U_B	20 - 30 V d.c., reverse polarity protection
voltage ripple	± 10 %
no-load current consumption	≤ 25 mA
type of connection	3-pin M8 initiator plug

sks-15/D

outputs

output 1	switching output pnp: $I_{\max} = 200 \text{ mA}$ ($U_B = 2\text{V}$) NOC/NCC adjustable, short-circuit-proof
switching hysteresis	2.0 mm
switching frequency	25 Hz
response time	32 ms
delay prior to availability	< 300 ms

housing

material	ABS
ultrasonic transducer	polyurethane foam, epoxy resin with glass contents
class of protection to EN 60529	IP 67
operating temperature	-25°C to +70°C
storage temperature	-40°C to +85°C
weight	8 g

technical features/characteristics

temperature compensation	no
controls	1 push-button
scope for settings	Teach-in via push-button
Synchronisation	no
multiplex	no
indicators	1 x LED green: working, 1 x LED yellow: switch status
particularities	minimum cuboidal design narrow sound field

pin assignment

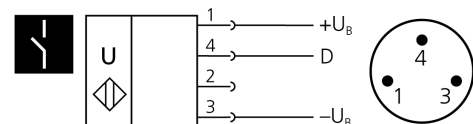

order no.

sks-15/D

The content of this document is subject to technical changes.
Specifications in this document are presented in a descriptive way
only. They do not warrant any product features.