

Click fittings NPKA



Click fittings NPKA

Key features



Application



Effortless selection of the right fitting. Festo offers a secure solution for every connection. The convenient push-in fitting system includes well over 1000 types of standard and function fittings.

Summary of tubing/fitting combinations			
Applications	Fitting	Tubing	Description
Standard	QS	PEN	Suitable for a wide range of tasks and attractively priced. Flexible thanks to high levels of resistance, easy to install thanks to optimised bending radii. High level of abrasion resistance in dynamic applications.
	QS	PUN	Maximum flexibility in standard applications thanks to an extremely wide range of options for combining the different types.
	QS	PAN	Meets all requirements, even for standard applications with increased pressure and temperature ranges.
High pressures	NPQM	PAN-MF	Meets DIN standard 73378: ideal for use in mobile pneumatics. Suitable for increased temperature ranges combined with high pressure ranges.
	NPQH	PAN-R	Powerful in pressure ranges up to 20 bar, for example in applications with the pressure booster DPA.
Resistant to chemicals, food safe and hydrolysis resistant	NPQP	PLN	Resistant to cleaning agents, FDA compliant and economical. Can be used instead of the combination with stainless steel fittings.
	NPKA	PUN-H	Hydrolysis resistant and suitable for water applications. Combination suitable for use in clean rooms, FDA compliant and corrosion resistant as it is made of 100% polymer. Very easy to install thanks to the "one click principle".
	NPQH	PFAN/PTFEN	For high temperatures up to 150 °C. Food safe, FDA compliant and resistant to cleaning agents.
	NPCK	PFAN/PTFEN	Easy to clean thanks to the union nut's edge-free design. Maximum resistance to corrosion (CRC 4) and FDA compliant. Suitable for a wide range of media.
	CRQS	PFAN/PTFEN	Maximum resistance to corrosion (CRC 4) and to aggressive acids and alkalis.
Resistant to chemicals and hydrolysis resistant	NPQR	PFAN/PTFEN	Optimised design, reduction in edges where dirt can collect – all at an attractive price. For high temperatures up to 150 °C. Pressure range up to 16 bar. Highest level of corrosion resistance (CRC 4).
Antistatic	NPQM	PUN-CM	Antistatic tubing plus solid metal fitting: maximum protection for electric and electronic components.
Flame retardant	NPQM	PUN-V0	Very safe in areas where there is a risk of fire thanks to flame-retardant properties. The tubing has been tested to DIN 5510-2.
Resistant to welding spatter	NPQH	PUN-V0-C	Ideal for applications involving welding spatter. Reliable thanks to a tubing wall thickness of 2 mm for all diameters.
	QS-V0	PAN-V0	Safe even in the close vicinity of welding spatter thanks to the double-walled tubing with special fitting.

Click fittings NPKA

Key features

FESTO

Push-in fittings product range

QSM, mini series



Technical data → Internet: qsm

Miniature push-in fittings for maximum component density in confined spaces. For pneumatic applications with a temperature range up to 80 °C and a pressure range up to 14 bar. Tubing outside diameters of 2, 3, 4 and 6 mm with connecting threads M3, M5, M6, M7, R $\frac{1}{8}$ and G $\frac{1}{8}$.

QS, standard series



Technical data → Internet: qs

Wide selection of push-in fittings for pneumatic applications with a temperature range up to 80 °C and a pressure range up to 14 bar. Tubing outside diameters of 4, 6, 8, 10, 12, 16 and 22 mm with connecting threads R $\frac{1}{8}$... R $\frac{1}{2}$ and G $\frac{1}{8}$... G $\frac{3}{4}$.

CRQS, stainless steel



Technical data → Internet: crqs

Stainless steel push-in fitting. High corrosion resistance CRC 4 and chemical resistance with approval for use in the food and packaging industry. For pneumatic applications with a temperature range up to 120 °C and a pressure range up to 10 bar. Tubing outside diameters of 4, 6, 8, 10, 12 and 16 mm with connecting threads M5 and R $\frac{1}{8}$... R $\frac{1}{2}$.

QS-V0, resistant to welding spatter



Technical data → Internet: qs-v0

Flame-retardant push-in fitting for use in all areas where there is a risk of fire, for example welding systems in the automotive industry and in the construction industry. For pneumatic applications with a temperature range up to 60 °C and a pressure range up to 10 bar. Tubing outside diameters of 4, 6, 8, 10 and 12 mm with connecting threads R $\frac{1}{8}$... R $\frac{1}{2}$ and G $\frac{1}{8}$... G $\frac{1}{2}$.

NPQH



Technical data → Internet: npqh

Solid metal push-in fitting made of chemically nickel-plated brass. High corrosion resistance CRC 3 and chemical resistance. For pneumatic applications with a temperature range up to 150 °C and a pressure range up to 20 bar. Tubing outside diameters of 4, 6, 8, 10, 12 and 14 mm with connecting threads M5, M7 and G $\frac{1}{8}$... G $\frac{1}{2}$.

NPQM



Technical data → Internet: npqm

Attractively priced metal push-in fitting for pneumatic applications with a temperature range up to 70 °C and a pressure range up to 16 bar. Tubing outside diameters of 3, 4, 6, 8, 10, 12 and 14 mm with connecting threads M5, M7 and G $\frac{1}{8}$... G $\frac{1}{2}$.

NPQP



Technical data → Internet: npqp

Polypropylene fitting for use in applications with extreme influence of media. For pneumatic applications with a temperature range up to 60 °C and a pressure range up to 10 bar. Tubing outside diameters of 4, 6, 8, 10 and 12 mm with connecting threads R $\frac{1}{8}$... R $\frac{1}{2}$.

NPQR, stainless steel



Technical data → Internet: npqr

Stainless steel push-in fitting. Maximum corrosion resistance CRC 4 and chemical resistance. For pneumatic applications with a temperature range up to 150 °C and a pressure range up to 16 bar. Tubing outside diameters of 4, 6, 8, 10 and 12 mm with connecting threads M5, M7 and G $\frac{1}{8}$... G $\frac{1}{2}$.

Click fittings NPKA

Key features

FESTO

Functional push-in fittings product range

QSK, self-sealing push-in fitting

Technical data → Internet: qsk



Push-in fitting that blocks the air flow after the tubing is disconnected. For pneumatic applications with a temperature range up to 60 °C and a pressure range up to 14 bar. Tubing O.D.∅ of 4, 6, 8, 10 and 12 mm with connecting threads M5, R1/8 ... R1/2 and G1/8 ... G1/2.

QSR, rotary push-in fitting

Technical data → Internet: qsr



Push-in fitting with swivel connection, rotatable by 360°. The ball bearing enables rotating movements in the application up to max. 500 rpm. For pneumatic applications with a temperature range up to 60 °C and a pressure range up to 14 bar. Tubing O.D.∅ of 4, 6, 8, 10 and 12 mm with connecting threads M5, R1/8 ... R1/2 and G1/8 ... G1/2.

Quick connectors product range

NPCK

Technical data → Internet: npck



Stainless steel fitting for use in areas subject to intensive cleaning. Highest level of corrosion resistance (CRC 4). For pneumatic applications with a temperature range up to 120 °C and a pressure range up to 12 bar. Tubing O.D. 6 mm with connecting thread G1/8.

Click fittings product range

NPKA

Technical data → Internet: npka



Plastic fitting for easy installation with one-hand operation. Hydrolysis resistant, FDA compliant and easy to clean. For pneumatic applications with a temperature range up to 60 °C and a pressure range up to 10 bar. Tubing O.D. 6 mm with connecting thread G1/8.

Click fittings NPKA

Key features

FESTO

Key features

The click fitting NPKA is safe for use in the food industry.

The NPKA is made entirely of plastic and is suited for use in areas subject to intensive cleaning.

- Quick and simple tube installation using one hand
- Reliable assembly: click sound indicates that the open or closed position has been reached

- Low leaking, no scratching of the tube by retaining claws
- Easy to clean, sealed shape when tube fitted
- Suitable for tubes with corresponding slot

Assembly:

- 1) Screw the threaded plug **1** and the sealing ring **2** on to the counterpart and tighten in accordance with the nominal tightening torque. Special feature of the straight design NPKA-D: insert long side of Allen key **3** completely into the click fitting through the sleeve **4**. Use the entire contact surface of the internal hexagon socket (→ Fig. 1).
- 2) Pull the sleeve **4** as far as the stop contour **1** **5** of the

clamping collet, until you hear and feel the sleeve click in.

- 3) Insert the plastic tubing **6** through the open sleeve **4**, clamping collet and tubing seal as far as the tube bearing shoulder (→ Fig. 2).
- 4) Push the sleeve as far as the stop contour **2** **7** of the clamping collet, until you hear and feel the sleeve click in (→ Fig. 3). The closed sleeve pushes the clamping segment of the clamping collet against the plastic tubing, holding it in place.

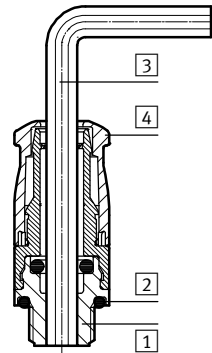

Fig. 1

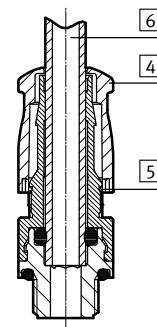

Fig. 2

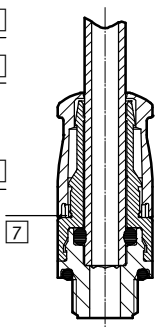

Fig. 3

Dismantling:

- 1) Dismantling is completed in reverse order to the assembly.

Click fittings NPKA

Technical data

FESTO

General technical data	
Size	Standard
Design	Push-pull principle
Assembly position	Any
Type of seal on threaded plug	Sealing ring
Max. tightening torque [Nm]	2
Nominal tightening torque [Nm]	1.25
Tolerance for nominal tightening torque [%]	±20
Tubing insertion depth [mm]	25.8
Suitable tubings	PAN, PAN-R, PAN-MF, PAN-VO, PFAN, PEN, PLN, PUN, PUN-DUO, PUN-CM, PUN-H, PUN-H-DUO, PUN-VO



Operating and environmental conditions	
Operating pressure [bar]	-0.95 ... +10
Operating medium	Compressed air in accordance with ISO 8573-1:2010 [7:-:-]
	Water as per manufacturer's declaration ¹⁾
Note on operating/pilot medium	Lubricated operation possible
Ambient temperature [°C]	-10 ... +60
Food-safe ¹⁾	See supplementary material information

1) Additional information www.festo.com/sp → Certificates.

Materials	
Sleeve	POM
Housing with clamping collet and threaded plug	PA66-GF30
Threaded seal	NBR
Tubing seal	NBR
Note on materials	RoHS-compliant

Click fittings NPKA

Product range overview

Design	Version	Type	Pneumatic connection D1		Pneumatic connection D2	→ Page/ Internet
			G thread	Tubing O.D.∅	Tubing O.D.∅	
Straight design	Click fitting – Male thread with internal hexagon					
		NPKA-D	G1/8	–	6	8
L-shape	Click L-fitting – Male thread with external hexagon, orientable					
		NPKA-L	G1/8	–	6	8
T-shape	Click T-connector					
		NPKA-T	–	6	6	9

Click fittings NPKA

Technical data



Click fitting NPKA-D

Male thread with internal hexagon

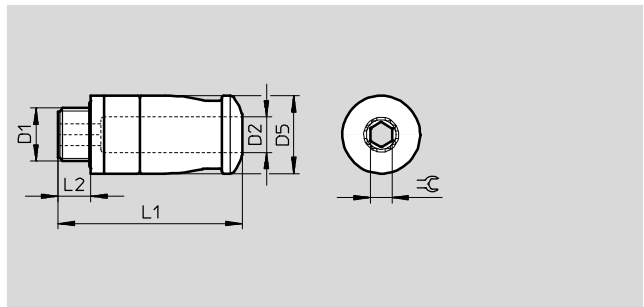

Pneumatic connection		Nominal size [mm]	D5 Ø	L1	L2	≈C1	Weight/ piece [g]	Part No.	Type	PU ¹⁾
Male thread D1	For tubing O.D. D2 [mm]									
G ¹ / ₈	6	4	14.2	33.6	6	4	4.2	1243489	NPKA-D-G18-Q6-P10	10

Download CAD data → www.festo.com

1) Packaging unit

Click L-fitting NPKA-L

Male thread with external hexagon, orientable

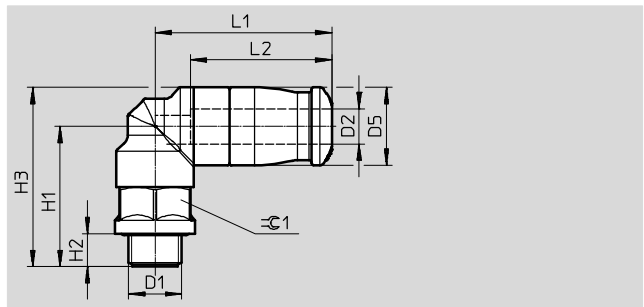

Pneumatic connection		Nominal size [mm]	D5 Ø	H1	H2	H3	L1	L2	≈C1	Weight/ piece [g]	Part No.	Type	PU ¹⁾
Male thread D1	For tubing O.D. D2 [mm]												
G ¹ / ₈	6	4	14.2	25.6	6	32.7	32.3	25.8	13	7.5	1655429	NPKA-L-G18-Q6-P10	10

Download CAD data → www.festo.com

1) Packaging unit

Click fittings NPKA

Technical data

Click T-connector NPKA-T

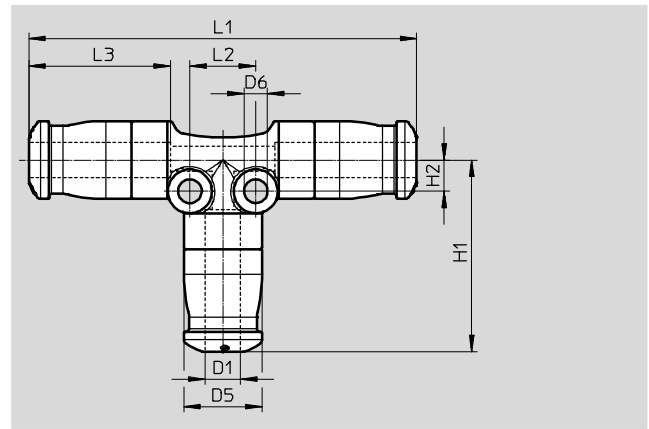

Dimensions and ordering data										Download CAD data → www.festo.com		
Pneumatic connection	Nominal size	D5	D6	H1	H2	L1	L2	L3	Weight/ piece	Part No.	Type	PU ¹⁾
For tubing O.D. D1 [mm]	[mm]	∅	∅						[g]			
6	4	14.2	4.3	35	5.7	70.6	12	25.8	12.5	1590710	NPKA-T-Q6-E-P10	10

1) Packaging unit

Festo - Your Partner in Automation



1 Festo Inc.
5300 Explorer Drive
Mississauga, ON L4W 5G4
Canada

Festo Customer Interaction Center
Tel: 1 877 463 3786
Fax: 1 877 393 3786
Email: customer.service.ca@festo.com



2 Festo Pneumatic
Av. Ceylán 3,
Col. Tequesquináhuac
54020 Tlalneantla,
Estado de México

Multinational Contact Center
01 800 337 8669
ventas.mexico@festo.com



3 Festo Corporation
1377 Motor Parkway
Suite 310
Islandia, NY 11749

Festo Customer Interaction Center
1 800 993 3786
1 800 963 3786
customer.service.us@festo.com



4 Regional Service Center
7777 Columbia Road
Mason, OH 45040

Connect with us



www.festo.com/socialmedia



www.festo.com

Subject to change